

Demolition Tools



**Built
to
Last!**

**Brunner
& Lay**

Introduction

Thank you for selecting Brunner & Lay for your Boom Mounted Demolition tools. We manufacture a wide range of high quality tools for pneumatic and hydraulic breaker machines currently in use worldwide.

All Brunner & Lay tools are manufactured and processed within the Company's modern factory, utilizing the latest machinery and technology to ensure that the finished products comply with the high standards of quality our customers expect.

Warranty

Brunner & Lay tools are guaranteed against defects in raw material and manufacture. No other warranty is implied or expressed. The Company's liability in respect of any warranty claims is limited to replacement and does not extend to any other expenditure incurred or to any consequential damage. Warranty claims are subject to immediate notification of any problems and return of the goods to Brunner & Lay under their Returned Goods Policy. See our Warranty Guide on page 19 and 20.

How to read B&L Part Numbers

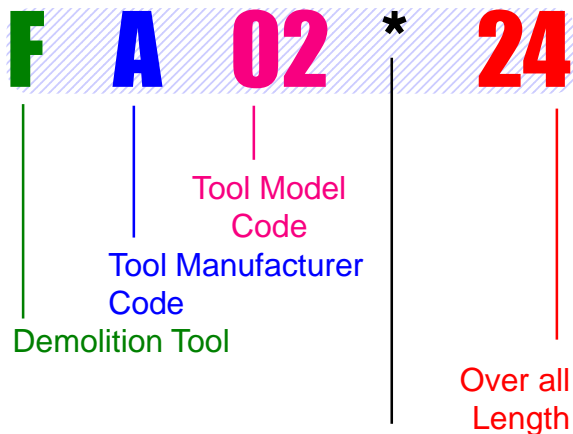

- * Replaced by one of the following
 - A = Asphalt Cutter
 - B = Blunt
 - P = Point

X = Cross Cut Chisel C = Inline Chisel

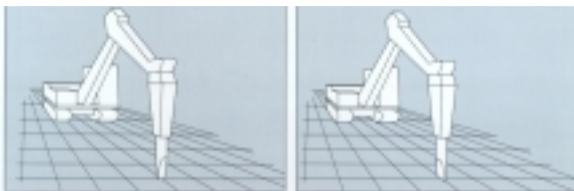

If the hammer you are using does not appear on this page, please contact our customer service representatives for assistance.



















1-(800)-872-6899

Catalog # BDT2000

Hammer Index



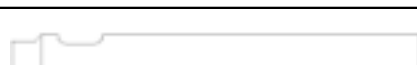

| Manufacturer | Page No. |
|-----------------------|--------------|
| Allied | 1-2 |
| Atlas Copco | 2 |
| B T I | 3 |
| Balderson | 4 |
| Caterpillar | 4 |
| Contech | 5 |
| Chicago Pneumatic | 5 |
| Daewoo | 6 |
| Dainong | 5 |
| D N B | 5 |
| Dynatech | 6 |
| Esco | 6 |
| Furukawa | 10-11 |
| Husky | 6 |
| Impulse | 6 |
| Indeco | 7 |
| Izumi | 6 |
| J C B | 8 |
| J R B | 9 |
| Kent | 10-11 |
| Krupp | 1-2 |
| Melroe | 16 |
| Montabert | 17 |
| N P K | 12 |
| Okada | 13 |
| Rammer | 15 |
| Roxon | 15 |
| Soosan | 15 |
| Stanley | 16 |
| Terminator | 3 |
| Toyo | 9 |
| Tramac | 17 |
| UB-Equipment | 18 |
| WARRANTY GUIDE | 19-20 |

ALLIED / Krupp





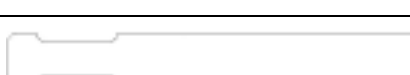
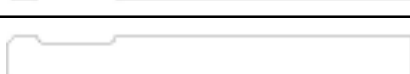
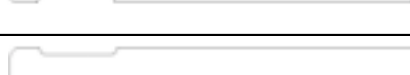

| | <i>Part No.</i> | <i>HAMMER MODEL</i> | <i>FINISH DIA.</i> | <i>O/A LENGTH</i> |
|---|-----------------|---------------------|--------------------|-------------------|
|  | FA02*24 | RAPID RAM 33 | 2.50 | 24 |
|  | FA03*30 | HY RAM 65/75 | 3.13 | 30 |
|  | FA04*32 | HY RAM 77 | 3.13 | 32 |
| | FA04*37 | HY RAM 77 | 3.13 | 37 |
|  | FA06*33 | HY RAM 88 | 3.93 | 33 |
| | FA06*39 | HY RAM 88 | 3.93 | 39 |
|  | FA08*32 | HO RAM 250 | 3.56 | 32 |
|  | FA11*18 | HY RAM 700 | 1.77 | 18 |
|  | FA12*24 | HY RAM 720 | 2.56 | 24 |
|  | FA13*18 | HY RAM 710 | 2.16 | 18 |
| | FA13*24 | HY RAM 710 | 2.16 | 24 |
|  | FA14*39 | HY RAM 750 | 4.50 | 39 |
| | FA14*45 | HY RAM 750 | 4.50 | 45 |
|  | FA15*39 | HY RAM 750B | 4.48 | 39 |
| | FA15*45 | HY RAM 750B | 4.48 | 45 |
|  | FA55*45 | HY RAM 755CS | 4.70 | 45 |
|  | FA16*44 | HY RAM 770 | 5.27 | 44 |
| | FA16*49 | HY RAM 770 | 5.27 | 49 |
|  | FA17*44 | HY RAM 770B | 5.28 | 44 |
| | FA17*49 | HY RAM 770B | 5.28 | 49 |
|  | FA18*29 | HO RAM 7000 | 3.93 | 29 |
| | FA18*35 | HO RAM 7000 | 3.93 | 35 |
|  | FA19*28 | HY RAM 715 | 2.55 | 28 |
| | FA19*32 | HY RAM 715 | 2.55 | 32 |
|  | FA20*29 | HO RAM 7000B | 3.93 | 29 |
| | FA20*36 | HO RAM 7000B | 3.93 | 36 |
|  | FA22*32 | HY RAM 730 | 3.13 | 32 |
| | FA22*36 | HY RAM 730 | 3.13 | 36 |
|  | FA24*33 | HY RAM 740 | 3.93 | 33 |
| | FA24*39 | HY RAM 740 | 3.93 | 39 |
|  | FA25*32 | HY RAM 725 | 2.94 | 32 |
| | FA25*36 | HY RAM 725 | 2.94 | 36 |

Insert Letter for * A=Asphalt Cutter (Special), B=Blunt, P=Point, X=Cross Cut Chisel, C=In Line Chisel

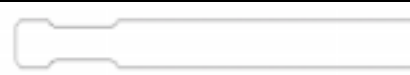
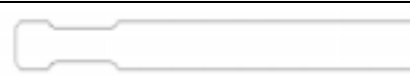
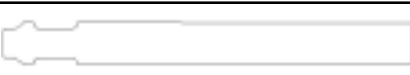
ALLIED / Krupp

| | <i>Part No.</i> | <i>HAMMER MODEL</i> | <i>FINISH DIA.</i> | <i>O/A LENGTH</i> |
|---|-----------------|---------------------|--------------------|-------------------|
|  | FA26*31 | HO RAM 300 | 3.50 | 31 |
|  | FA28*46 | HY RAM 780 / 785cs | 5.86 | 46 |
| | FA28*52 | HY RAM 780 / 785cs | 5.86 | 52 |
|  | FA10*46 | HY RAM 99 | 5.28 | 46 |
|  | FA21*24 | HY RAM 711B | 2.43 | 24 |
|  | FA29*55 | HY RAM 790/795 | 6.25 | 55 |
| | FA29*72 | HY RAM 790/795 | 6.25 | 72 |
|  | FA59*59 | HY RAM 800/805 | 7.05 | 59 |
| | FA59*72 | HY RAM 800/805 | 7.05 | 72 |
|  | FA31*47 | HY RAM 775cs | 5.50 | 47 |

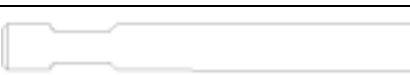







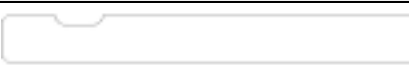

ATLAS COPCO

| | <i>Part No.</i> | <i>HAMMER MODEL</i> | <i>FINISH DIA.</i> | <i>O/A LENGTH</i> |
|---|-----------------|------------------------------------|--------------------|-------------------|
|  | FT80*22 | TEX 75H / 80H / 100H SBC-115 | 1.75 | 22 |
| | FT80*28 | TEX 75H / 80H / 100H SBC-115 | 1.75 | 28 |
|  | FT11*22 | TEX 110H/HS SBC-255 | 1.94 | 22 |
|  | FT18*24 | TEX 180H SBC-410 | 2.54 | 24 |
|  | FT25*32 | TEX 250H1 | 3.13 | 32 |
| | FT25*40 | TEX 250H1 | 3.13 | 40 |
|  | FT26*32 | TEX 250HS1 | 3.13 | 32 |
|  | FT40*33 | TEX 400H SBC-800 | 3.71 | 33 |
|  | FT60*36 | TEX 600 / 700 / 900H HBC-1100/1700 | 4.10 | 36 |
| | FT60*43 | TEX 600 / 700 / 900H HBC-1100/1700 | 4.10 | 43 |
|  | FT61*32 | SBC 610 | 3.13 | 32 |
|  | FT14*39 | TEX1400H HBC2500 | 4.89 | 39 |

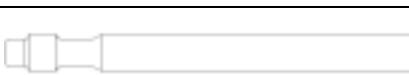
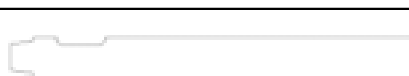
TERMINATOR

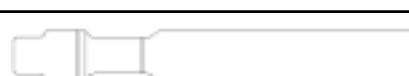
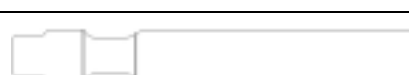
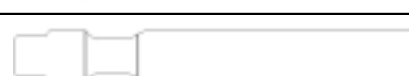



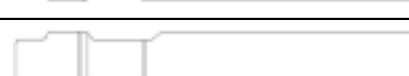





| | Part No. | HAMMER MODEL | FINISH DIA. | O/A LENGTH |
|---|----------|--------------|-------------|------------|
|  | FO20B31 | T2000 | 5.87 | 31 |

Breaker Technology, Inc.

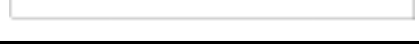
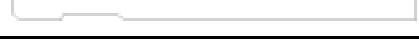
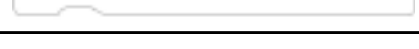
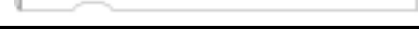

| | TELEDYNE / TOKU Part No. | HAMMER MODEL | FINISH DIA. | O/A LENGTH |
|---|-----------------------------|--|-------------|------------|
|  | FE16*22 | TR-100 | 2.08 | 22 |
|  | FE02*29 | TR-200 / 200X | 2.82 | 29 |
|  | FE04*33 | TR-400 / 400X | 3.51 | 33 |
|  | FE06*36 | TR-602M / 602X | 3.92 | 36 |
|  | FE08*36 | TR-700 / 700X | 4.31 | 36 |
|  | FQ12*20 | TB-120 / 125 | 1.95 | 20 |
|  | FQ18*24 | TB-180 / 225 | 2.28 | 24 |
|  | FQ22*26 | TB-220 / 325 | 2.95 | 26 |
| | FQ22*30 | TB-220 / 325 | 2.95 | 30 |
|  | FQ40*32 | TB-400 / 400X / 420 / 425 / 425X / 625 | 3.75 | 32 |
|  | FQ72*36 | TB-700/700X/725/725X/750X/825/825X/830 | 4.51 | 36 |
|  | FQ90*46 | TB-900/925/950/975/980/995/1025 | 5.30 | 46 |
| | FQ90*52 | TB-900/925/950/975/980/995/1025 | 5.30 | 52 |
|  | FQ130*48 | TB-1300/1425 | 5.75 | 48 |
|  | FQ16*48 | TB-1680 | 5.75 | 48 |
|  | FQ20*60 | TB1830/2080 | 6.28 | 60 |
|  | FQ25*62 | TB-2580 | 6.98 | 62 |

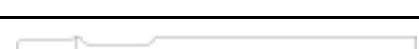
Insert Letter for * A=Asphalt Cutter (Special), B=Blunt, P=Point, X=Cross Cut Chisel, C=In Line Chisel







CATERPILLAR / BALDERSON

| | Part No. | HAMMER MODEL | FINISH DIA. | O/A LENGTH |
|---|----------|-----------------|-------------|------------|
|  | FS23*26 | B-63 | 2.47 | 26 |
|  | FS52*36 | B-110 | 4.31 | 36 |
|  | FS66*41 | 320 / 120 | 4.52 | 41 |
|  | FS64*41 | 320 / 312 / 115 | 4.17 | 41 |
|  | FS54*41 | B-115 | 4.51 | 41 |
|  | FS68*43 | 325/320/130 | 5.08 | 43 |
|  | FS56*43 | B-130 | 5.12 | 41 |
|  | FS83*47 | 330/325/140 | 5.50 | 47 |
|  | FS84*52 | 350/160 | 6.30 | 52 |
|  | FS10*57 | 375/180 | 6.64 | 57 |
|  | FS12*67 | B-195 | 7.63 | 67 |
|  | FS25*29 | E70B/70 | 2.74 | 29 |
|  | FS26*33 | B-90 | 3.50 | 33 |





CONTECH

| | Part No. | HAMMER MODEL | FINISH DIA. | O/A LENGTH |
|---|----------|--------------|-------------|------------|
|  | FF06*27 | HD-3 | 2.50 | 27 |
|  | FF08*32 | HD-6 | 3.50 | 32 |
|  | FF10*27 | 125 MINI RAM | 2.52 | 27 |

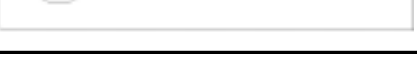
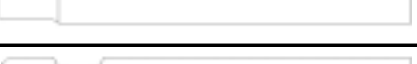
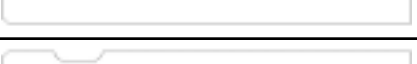

CHICAGO PNEUMATIC

| | Part No. | HAMMER MODEL | FINISH DIA. | O/A LENGTH |
|---|----------|--------------------|-------------|------------|
|  | FT11*21 | 110H | 1.95 | 21 |
|  | FT18*24 | 180H | 2.53 | 24 |
|  | FT25*32 | 250H1 | 3.13 | 32 |
|  | FT80*22 | 75H / 80H / 100H | 1.75 | 22 |
|  | FT40*33 | 400H | 3.71 | 33 |
|  | FT60*36 | 600H / 700H / 900H | 4.10 | 36 |
|  | FT14*40 | 1400H | 4.89 | 39 |

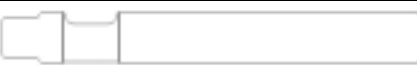

DAINONG / DNB

| | Part No. | HAMMER MODEL | FINISH DIA. | O/A LENGTH |
|---|----------|--------------|-------------|------------|
|  | FS83*47 | D-110 | 5.50 | 47 |
|  | FS86*52 | D-160 | 6.65 | 52 |
|  | FS23*26 | D-30 | 2.47 | 26 |
|  | FS26*33 | D-50 | 3.50 | 33 |
|  | FS54*41 | D-60 | 4.51 | 41 |
|  | FS56*41 | D-70 / D-90 | 5.12 | 41 |





DYNATECH

| | Part No. | HAMMER MODEL | FINISH DIA. | O/A LENGTH |
|---|----------|--------------|-------------|------------|
|  | FD20*30 | TB 280B | 2.75 | 30 |
|  | FD58*28 | TB 580 D | 2.90 | 28 |

Esco

| | Part No. | HAMMER MODEL | FINISH DIA. | O/A LENGTH |
|---|----------|-----------------------|-------------|------------|
|  | FR14*20 | ES-14 (2-3/4" Collar) | 2.22 | 20 |
|  | FR02*23 | ES-20/30 (3" Collar) | 2.48 | 23 |
| | FR02*28 | ES-20/30 (3" Collar) | 2.48 | 28 |
|  | FR35*29 | ES-35 | 2.75 | 29 |







HUSKY / Izumi / Daewoo

| | Part No. | HAMMER MODEL | FINISH DIA. | O/A LENGTH |
|--|----------|--------------|-------------|------------|
|  | FY15*20 | HH150 | 1.97 | 20 |
|  | FY30*24 | HH300 | 2.36 | 24 |
|  | FY50*24 | HH500 | 2.56 | 24 |
|  | FY75*30 | HH750 | 2.95 | 30 |
|  | FY10*34 | HH1000 | 3.54 | 34 |

IMPULSE



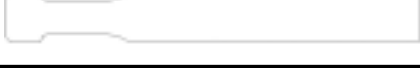
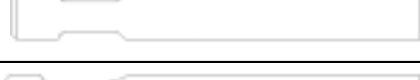
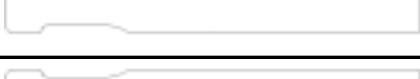
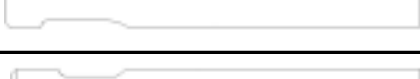

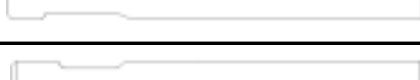
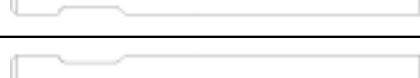
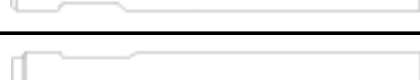
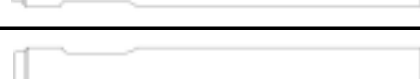
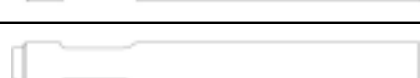
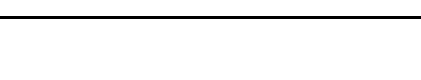







| | Part No. | HAMMER MODEL | FINISH DIA. | O/A LENGTH |
|---|----------|--------------|-------------|------------|
|  | FR02*23 | 360V | 2.50 | 23 |
| | FR02*28 | 360V | 2.50 | 28 |

INDECO

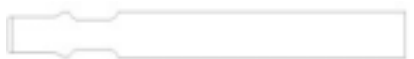





| | Part No. | HAMMER MODEL | FINISH DIA. | O/A LENGTH |
|---|-----------------|----------------------|--------------------|-------------------|
|  | FU18*22 | MES 180 / 181 / 200 | 1.86 | 22 |
|  | FU03*23 | MES 300 / 301 / 350 | 2.16 | 23 |
|  | FU05*26 | HB 5 / MES 521 / 550 | 2.53 | 26 |
|  | FU55*27 | MES 553/523 | 2.90 | 27 |
|  | FU08*28 | HB 8 | 3.12 | 28 |
|  | FU62*32 | MES 601/621 | 3.11 | 32 |
|  | FU12*30 | HB 12 / MES 1200 | 3.50 | 30 |
|  | FU15*36 | HB-19 / MES 1500 | 4.28 | 36 |
|  | FU17*39 | MES 1750 / 1800 | 4.47 | 39 |
|  | FU20*46 | MES-2000 / HB-27 | 4.67 | 46 |
|  | FU25*42 | MES 2500 | 5.11 | 42 |
|  | FU30*43 | MES 3000 | 5.50 | 43 |
|  | FU35*46 | MES 3500 | 5.64 | 46 |
|  | FU50*52 | MES 5000 | 6.22 | 52 |
|  | FU70*57 | MES 7000 | 7.08 | 57 |

Insert Letter for * A=Asphalt Cutter (Special), B=Blunt, P=Point, X=Cross Cut Chisel, C=In Line Chisel

J C B

| | Part No. | HAMMER MODEL | FINISH DIA. | O/A LENGTH |
|---|-----------------|---------------------|------------------------|-----------------------|
|  | FS21*19 | JCB 160 | 1.76 | 19 |
|  | FS23*26 | JCB 260/260L | 2.47 | 26 |
|  | FS25*29 | JCB 360/360Q | 2.74 | 29 |
|  | FC06*32 | JCB 380 | 3.13 | 32 |
|  | FS26*33 | JCB 460 | 3.50 | 33 |
|  | FC08*39 | JCB 480 | 3.71 | 39 |
|  | FS54*41 | JCB 560 | 4.51 | 41 |
|  | FC11*50 | JCB 630 | 4.63 | 50 |
|  | FS66*41 | JCB 660 | 4.52 | 41 |
|  | FC20*43 | JCB 690 | 4.78 | 43 |
|  | FS56*41 | JCB 760 | 5.12 | 41 |
|  | FS83*47 | JCB 860 | 5.50 | 47 |
|  | FS84*52 | JCB 960 | 6.30 | 52 |







JRB / TOYO / TAKEUCHI

| | Part No. | HAMMER MODEL | FINISH DIA. | O/A LENGTH |
|---|-----------------|----------------------|------------------------|-----------------------|
|  | FV31*30 | JKHB 301 / THBB301 | 2.74 | 30 |
|  | FV40*35 | JKHB 401 / THBB401 | 3.13 | 35 |
|  | FV80*38 | JKHB 801 / THBB801 | 3.90 | 38 |
|  | FV15*44 | JKHB1500 / THBB1600 | 5.36 | 44 |
|  | FV20*49 | JKHB 2000 / THBB2000 | 5.90 | 49 |
|  | FV30*55 | JKHB 3000 / THBB3000 | 6.28 | 55 |



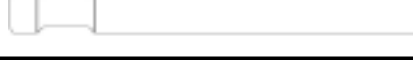
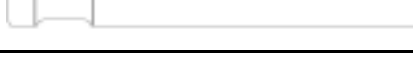
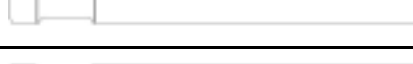
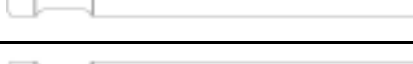
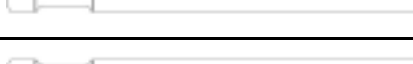
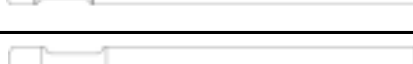
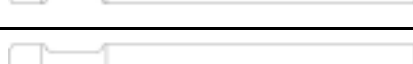

KENT / FURUKAWA

| | Part No. | HAMMER MODEL | FINISH DIA. | O/A LENGTH |
|--|----------|------------------------|-------------|------------|
| | FB02*30 | KB 555 (2 1/2" DIA.) | 2.50 | 30 |
| | FB02*36 | KB 555 (2 1/2" DIA.) | 2.50 | 36 |
| | FB04*30 | KB 555 (3" DIA.) | 3.00 | 30 |
| | FB06*30 | KB 999 | 3.48 | 30 |
| | FB06*36 | KB 999 | 3.48 | 36 |
| | FB06*48 | KB 999 | 3.48 | 48 |
| | FB08*48 | KB 2000/2600 | 5.21 | 48 |
| | FB54*22 | KF 4 | 2.35 | 22 |
| | FB60*29 | KF 6 | 2.93 | 29 |
| | FB09*30 | KF 9 | 3.50 | 30 |
| | FB09*34 | KF 9 | 3.50 | 34 |
| | FB09*72 | KF 9 | 3.50 | 72 |
| | FB52*43 | KF 12 | 4.11 | 43 |
| | FB19*48 | KF 19 | 4.70 | 48 |
| | FB22*49 | KF 22 | 5.28 | 49 |
| | FB85*55 | KF 35 | 5.87 | 55 |
| | FB95*60 | KF 45 | 6.48 | 60 |
| | FB10*19 | KHB 100 | 2.14 | 19 |
| | FB12*24 | KHB 200 | 2.74 | 24 |
| | FB14*32 | KHB 400 | 3.71 | 32 |
| | FB16*36 | KHB 700 | 4.12 | 36 |
| | FB18*47 | KHB 1100 / 1600 | 5.09 | 47 |





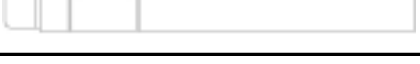
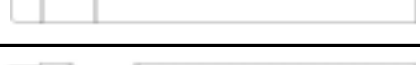
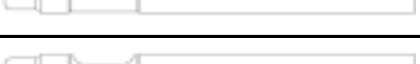
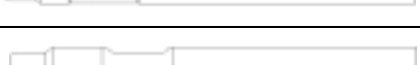
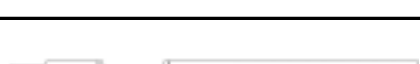
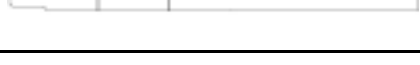
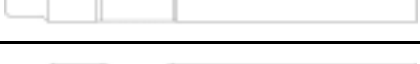
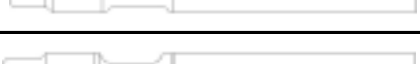
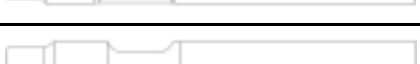
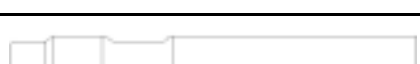







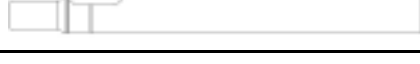
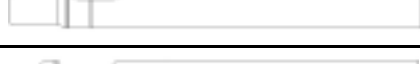
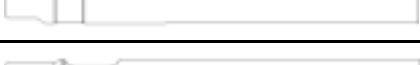
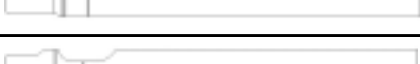
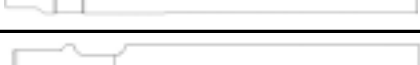
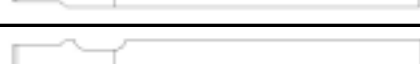

KENT / FURUKAWA

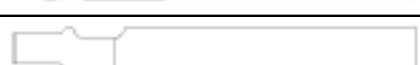
| | Part No. | HAMMER MODEL | FINISH DIA. | O/A LENGTH |
|---|----------|-----------------|-------------|------------|
|  | FB20*48 | KHB 1200 / 1500 | 5.47 | 48 |
|  | FB01*16 | KHB 1G | 1.42 | 16 |
|  | FB23*18 | KHB 2G | 1.77 | 18 |
|  | FB25*23 | KHB 3G | 2.35 | 23 |
|  | FB30*25 | KHB 5G | 2.93 | 25 |
|  | FB35*29 | KHB 8G | 3.52 | 29 |
|  | FB38*40 | KHB 10G | 4.11 | 40 |
|  | FB40*43 | KHB 15G | 4.68 | 43 |
|  | FB45*48 | KHB 20G | 5.28 | 48 |
|  | FB31*51 | KHB 30G | 5.87 | 51 |
|  | FB41*55 | KHB 40G | 6.28 | 55 |
|  | FB50*60 | KHB 50G | 7.06 | 60 |

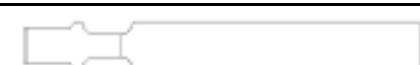
N.P.K.

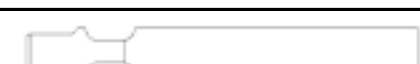
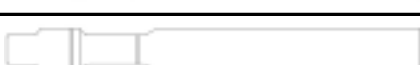













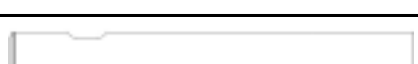

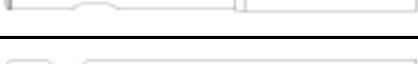
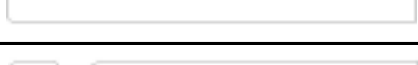
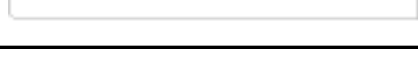
| | Part No. | HAMMER MODEL | FINISH DIA. | O/A LENGTH |
|---|----------|--------------|-------------|------------|
|  | FM04*23 | H1XA | 2.22 | 23 |
|  | FM06*30 | H2XA | 2.54 | 30 |
|  | FM08*28 | H3XA | 2.93 | 28 |
|  | FM10*30 | H4XE | 3.50 | 30 |
|  | FM11*36 | H6X | 3.75 | 36 |
|  | FM15*36 | H6XA | 3.75 | 36 |
|  | FM12*36 | H7X | 4.14 | 36 |
|  | FM14*38 | H8XA | 4.54 | 38 |
|  | FM16*43 | H10XB | 4.93 | 43 |
| | FM16*47 | H10XB | 4.93 | 47 |
| | FM16*50 | H10XB | 4.93 | 50 |
|  | FM18*47 | H12X | 5.32 | 47 |
|  | FM19*47 | E12X | 4.94 | 47 |
|  | FM20*51 | H16X | 5.71 | 51 |
|  | FM28*52 | H20X | 6.09 | 52 |
|  | FM30*61 | H30X | 6.86 | 61 |
|  | FM21*47 | E213 | 5.32 | 47 |

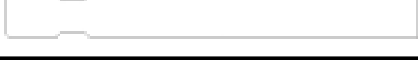
OKADA

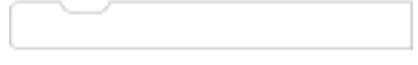

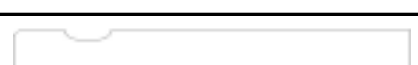

| | Part No. | HAMMER MODEL | FINISH DIA. | O/A LENGTH |
|---|----------|--------------|-------------|------------|
|  | FP02*21 | UB-2 | 2.16 | 21 |
|  | FP04*28 | UB-4 | 2.67 | 28 |
|  | FP06*31 | UB-5 | 3.14 | 31 |
|  | FP08*35 | UB-8 | 3.84 | 35 |
|  | FP10*44 | UB-11 | 4.81 | 44 |
|  | FP12*47 | UB-14 | 5.34 | 47 |
|  | FP14*48 | UB-17 | 5.42 | 48 |
|  | FP21*20 | UB-301 | 1.97 | 20 |
|  | FP22*22 | UB-302 | 2.40 | 22 |
|  | FP41*24 | UB-302a | 2.40 | 24 |
|  | FP23*28 | UB-303 | 2.67 | 28 |
|  | FP24*28 | UB-304 | 2.91 | 28 |
|  | FP34*30 | UB-304b | 2.91 | 30 |
|  | FP25*36 | UB-305 | 3.32 | 36 |
|  | FP26*32 | UB-306 | 3.34 | 32 |
|  | FP28*39 | UB-308 | 4.33 | 39 |
|  | FP30*43 | UB-310 | 4.80 | 43 |
|  | FP32*45 | UB-312 | 5.11 | 45 |
|  | FP36*51 | UB-316 | 5.50 | 51 |
|  | FP38*52 | UB-318 | 5.90 | 52 |

Insert Letter for * A=Asphalt Cutter (Special), B=Blunt, P=Point, X=Cross Cut Chisel, C=In Line Chisel



RAMMER / ROXON

| | Part No. | HAMMER MODEL | FINISH DIA. | O/A LENGTH |
|---|----------|--------------------|-------------|------------|
|  | FS64*41 | E-64 | 4.17 | 41 |
|  | FS68*43 | E-68 | 5.08 | 43 |
|  | FS80*47 | G-80 | 5.50 | 47 |
|  | FS80S43 | G-80 (Super Blunt) | 5.50 | 43 |
|  | FS90*52 | G-90 | 6.25 | 52 |
|  | FS10*57 | G-100 | 6.64 | 57 |
|  | FS10S50 | G100 (Super Blunt) | 6.64 | 47 |
|  | FS12*67 | G-120 | 7.63 | 50 |
|  | FS21*19 | S-21 | 1.76 | 19 |
|  | FS20*21 | S-20 | 2.08 | 21 |
|  | FS22*21 | S-22 | 1.96 | 21 |
|  | FS23*26 | S-23 | 2.47 | 26 |
|  | FS24*29 | S-24 | 2.83 | 29 |
|  | FS25*29 | S-25 | 2.74 | 29 |
|  | FS26*33 | S-26 | 3.50 | 33 |
|  | FS27*33 | S-27 | 3.30 | 33 |
|  | FS86*52 | S-41 S-86 / S2000 | 6.65 | 52 |
|  | FS52*36 | S-52 | 4.31 | 36 |
|  | FS54*41 | S-54 / S-700 | 4.51 | 41 |
|  | FS66*41 | S-55 / E-66 | 4.52 | 41 |





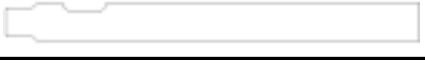













RAMMER / ROXON

| | Part No. | HAMMER MODEL | FINISH DIA. | O/A LENGTH |
|---|----------|--------------|-------------|------------|
|  | FS56*41 | S-56 | 5.12 | 41 |
|  | FS82*47 | S-82 S-1400 | 5.50 | 47 |
|  | FS83*47 | S-83 | 5.50 | 47 |
|  | FS84*52 | S-84 | 6.30 | 52 |
|  | FS29*36 | S-29 | 3.75 | 36 |













SOOSAN

| | Part No. | HAMMER MODEL | FINISH DIA. | O/A LENGTH |
|--|----------|--------------|-------------|------------|
|  | FN30*40 | SB-50 | 3.91 | 40 |
|  | FN40*28 | SB-40 | 2.67 | 28 |
|  | FN80*47 | SB-80 | 5.50 | 47 |



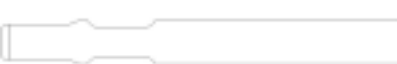
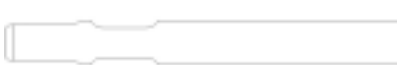

STANLEY / MELROE

| | Part No. | HAMMER MODEL | FINISH DIA. | O/A LENGTH |
|---|----------|-------------------------|----------------|---------------|
|  | FN30*40 | MB30EX | 3.91 | 40 |
|  | FN50*51 | MB-50EX | 5.50 | 51 |
|  | FN70*59 | MB-70EX | 6.07 | 59 |
|  | FN11*63 | MB-100EX | 6.85 | 63 |
|  | FN01*17 | MB-125 / 1250 | 1.75 | 17 |
|  | FL02*22 | MB-250 / 256 / 350 / 25 | 2.50 | 22 |
|  | FL02*31 | MB-250 / 256 / 350 / 25 | 2.50 | 31 |
|  | FL02*39 | MB-250 / 256 / 350 / 25 | 2.50 | 39 |
|  | FL04*28 | MB-550 / 5500 | 2.75 | 28 |
|  | FN07*28 | MB-656 / 675 / 695 | 2.99 | 28 |
|  | FN08*36 | MB-1200 / 1200C | 3.98 | 36 |
|  | FN10*41 | MB-1850 | 4.51 | 41 |
|  | FN12*41 | MB-2850/2875 | 5.11 | 41 |
|  | FN18*49 | MB-3900 / 3950 | 5.50 | 49 |
|  | FN28*30 | MB-800 / 875 | 3.12 | 30 |
|  | FN09*36 | MB-1500 / 1550 | 3.98 | 36 |
|  | FN16*17 | MB-1560 | 1.75 | 17 |
|  | FN19*41 | MB-1950 / 1975 | 4.50 | 41 |
|  | FN14*43 | MB-2950/2975 | 5.11 | 43 |







TRAMAC / MONTABERT

| | Part No. | HAMMER MODEL | FINISH DIA. | O/A LENGTH |
|---|----------|-----------------------|----------------|---------------|
|  | FC30*16 | BRP-30 | 1.57 | 16 |
|  | FC04*20 | BRH-40 | 1.79 | 20 |
|  | FC05*17 | BRP-45/50 | 1.96 | 17 |
| | FC05*25 | BRP-45/50 | 1.96 | 25 |
|  | FC15*20 | BRP-60/70 | 1.96 | 20 |
|  | FC07*24 | BRP-85/95/100 | 2.44 | 24 |
|  | FC16*23 | BRH-75 / 76 / 90 / 91 | 2.36 | 23 |
| | FC16*32 | BRH-75 / 76 / 90 / 91 | 2.36 | 32 |
|  | FC06*26 | BRH-125 | 3.13 | 26 |
| | FC06*32 | BRH-125 | 3.13 | 32 |
| | FC06*37 | BRH-125 | 3.13 | 37 |
| | FC06*48 | BRH-125 | 3.13 | 48 |
|  | FC08*34 | BRH-250 /400 / 450 | 3.72 | 34 |
| | FC08*39 | BRH-250 /400 / 450 | 3.72 | 39 |
| | FC08*47 | BRH-250 /400 / 450 | 3.72 | 47 |
|  | FC09*28 | BRP-130/140/150 | 2.90 | 28 |
| | FC09*38 | BRP-130/140/150 | 2.90 | 38 |
|  | FC10*39 | BRH-501/570 | 4.47 | 39 |
| | FC10*50 | BRH-501/570 | 4.47 | 50 |
|  | FC60*40 | BRM-600 | 4.12 | 40 |
|  | FC18*39 | BRH-620 | 4.52 | 39 |
|  | FC11*39 | BRH-625/900 | 4.63 | 39 |
| | FC11*50 | BRH-625/900 | 4.63 | 50 |
|  | FC12*44 | BRH-750 | 4.70 | 44 |
| | FC12*50 | BRH-750 | 4.70 | 50 |
|  | FC20*43 | BRV-32 / 950 | 4.78 | 43 |
| | FC20*50 | BRV-32 / 950 | 4.78 | 50 |

TRAMAC / MONTABERT

| | Part No. | HAMMER MODEL | FINISH DIA. | O/A LENGTH |
|---|----------|--------------|----------------|---------------|
|  | FC14*52 | BRH-1100 | 5.50 | 52 |
|  | FC43*49 | BRV-42 / 43 | 5.89 | 49 |
|  | FC22*52 | BRV-52 | 6.36 | 52 |
|  | FC23*49 | BRV-53 | 6.68 | 49 |
| | FC23*59 | BRV-53 | 6.68 | 59 |
|  | FC02*28 | Z-96 | 2.34 | 28 |
| | FC02*36 | Z-96 | 2.34 | 36 |

UB-EQUIPMENT

| | Part No. | HAMMER MODEL | FINISH DIA. | O/A LENGTH |
|---|----------|-----------------|----------------|---------------|
|  | FP51*33 | CMB JA04 | 3.55 | 33 |
|  | FP03*24 | CMB-35 / CMB-38 | 2.36 | 24 |
|  | FP18*46 | CMB JA8 | 5.31 | 46 |
|  | FP52*36 | CMB JA12 | 3.85 | 36 |
|  | FP53*50 | CMB JA33 | 6.10 | 50 |
|  | FP55*52 | CMB JA55 | 5.87 | 52 |

Warranty Guide

The purpose of this guide is to enable you to advise your customers as to the correct application of Brunner & Lay Demolition Tools and assist you in resolving complaints immediately .

When a tool has apparently failed to give satisfactory service life, a visual inspection often quickly resolves the cause and saves transport costs and frustration when warranty is rejected.

How a Demolition Tool Breaks Rock and Concrete

When the hammer piston strikes the top of a demolition tool, it sends a compressive stress wave down to the working end of the tool. Provided the demolition tool is in contact with the rock or concrete which requires breaking, it is this compressive stress wave which fractures the rock. Immediately following the compressive stress wave, a tensile stress wave is formed due to the hammer position lifting from the top of the demolition tool. This cycle of compressive and tensile stresses flowing down the tool is repeated for each hammer blow.

Obviously, anything that interferes with the 'strength' of the compressive stress wave during service, for example 'free running' or bending of the demolition tool due to leverage, will result in loss of breaker efficiency of up to 80% and possible fatigue failure of the tool itself.

Cause and Effect of Fatigue

The continuous cycle of compressive and tensile stresses in the demolition tool, even under correct operating conditions, create fatigue stress in the tool which can lead to the fatigue failure of a demolition tool before it is worn out. Again, anything which interferes with the cycle of compressive and tensile stresses will also increase the level of fatigue stress being applied to the demolition tool and thus increase the risk of early fatigue failure of the tool.

1. The main cause of increased fatigue stress in a demolition tool is any form of side pressure during service which creates bending

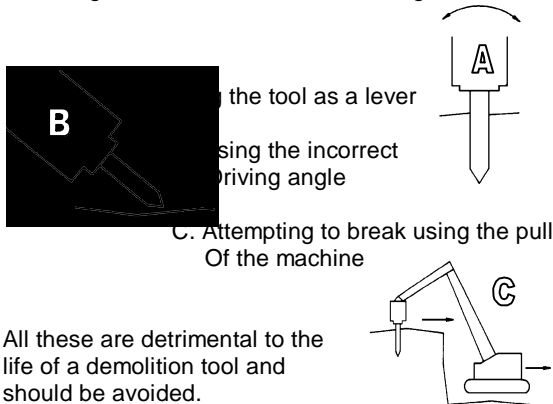

Remember, the hydraulic power available in the machine far exceeds the strength of a demolition tool if it is being used incorrectly and can "snap the tool like a carrot".

2. Other causes of increased fatigue stress in a demolition tool include:

A. 'Free Running'

In general this is any situation where the hammer piston strikes the top of the demolition tool, but the working end is not in proper contact with the rock or concrete to be broken. This includes jobs where the tool slides off the work and also when break-through of thin concrete slabs or boulders occurs.

B. Cold

Low temperature causes a demolition tool to be more susceptible to fatigue failure. Tools should be warmed before use.

C. Mechanical and thermal damage

Any form of damage to the surface of a demolition tool renders it more liable to suffer fatigue failure. Thus all care must be exercised to prevent accidental gouging, or contact welding ('galling' or 'pick-up') due to contact between the tool and chuck bushings through the lack of lubrication or excessive bending.

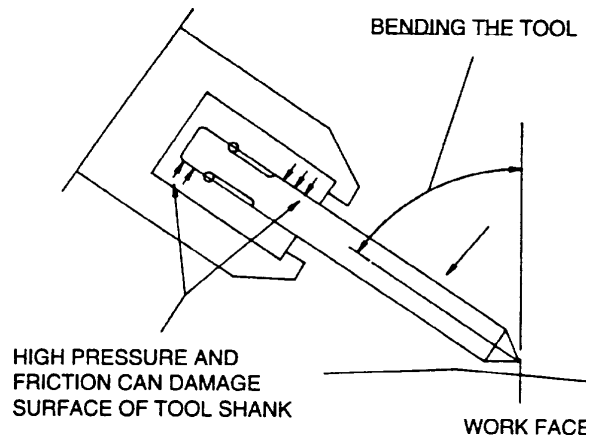

D. Lubrication

Care must be taken to avoid metal to metal contact that, as a result of galling or pick-up, could cause deep damage marks which, in turn, lead to the formation of fatigue cracks and eventual failure of the demolition tool. Ensure that the shank of the demolition tool is well lubricated before locating in the machine. Molybdenum bisulphide grease is recommended for this application at three hour intervals or as per manufacturers instructions.

E. Corrosion

A rusty demolition tool is more likely to suffer fatigue failure, thus keep tools well greased and sheltered from the weather when not in use.

Continued on page 20

Demolition Tool Fatigue Failure

A demolition tool fatigue failure will generally occur approximately 4" (100mm) either side of the chuck from face or through the retainer pin flat.

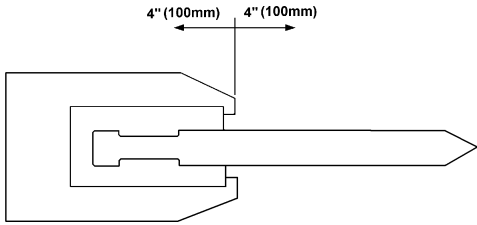

Another slightly less common failure area can fall approximately 8" (200mm) from the working end, subject to nature of use.

The fracture face itself will normally exhibit a semi circular polished area with the remainder being of a rougher appearance.

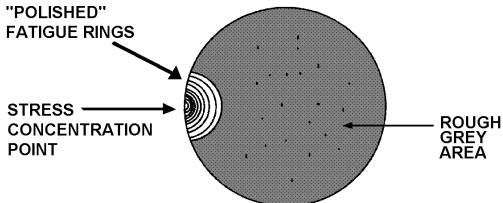

The "polished" semi-circular area in the above drawing, represents the fatigue area and generally starts from a damage mark or other stress raiser on the outside of the demolition tool and spreads inwards. The fatigue area slowly widens until the stresses being applied to the demolition tool cause sudden failure of the remaining section.

Generally, the size of the fatigue area indicates the level of stress applied to the tool, i.e. the smaller the fatigue area, the higher the stress level, although it must be borne in mind that once initiation of a fatigue crack has taken place, it requires a lower stress level to cause it to grow.

Typical Failures (guide to warranty claims)

Brunner & Lay demolition tools are manufactured from high quality materials and then heat treated to produce a fatigue and wear resistant tool. Thus when a tool has apparently failed to give a satisfactory service life, a brief visual inspection can often give a quick indication of cause. Below you will find typical fractures caused by excessive bending of the demolition tool. Warranty claims rejected.

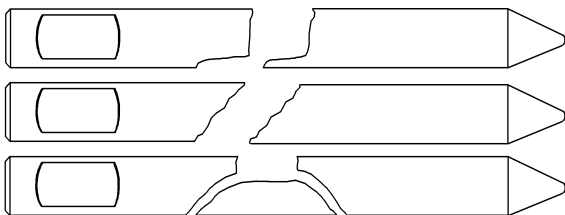

Typical of high stress fracture, usually caused by using the machine to "pull". Warranty claims rejected.

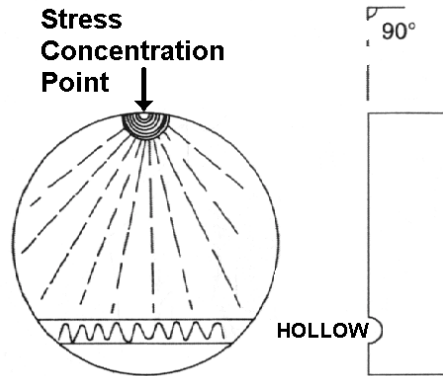

Typical fracture caused by levering tool while buried in the burden. Warranty claims rejected.



Wear

Wear is influenced by ground conditions, but as a general guide the following applies:

Blank tools worn more than 1/3 diameter or moils and chisels worn back more than 2" (51mm) of working end are classed as reasonable life. Warranty claim rejected.

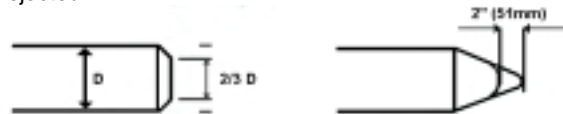

Mushrooming; this is caused by driving the point into hard dense material for too long a period of time without penetration. This generates intense heat softening the point, thus causing it to 'mushroom'. This is not a manufacturing fault. Warranty claims rejected.



Note fatigue lines originate from internal point, not outer diameter. Very rare failure type due to steel defect. 100% warranty accepted.



NEW

You can now place your orders

ON-LINE

www.brunnerlay.com

E-Mail: Sales@brunnerlay.com

**Located to give you the service
you expect!**

1-800-872-6899

Arkansas, Springdale 72765
1510 N. Old Missouri Rd. 72765-1190
P (501)-756-0880 F (501)756-5366

California, Los Angeles 90058
2425 E. 37th Street
P (323)-587-1233 F (323)-587-7513

Colorado, Denver 80212
5338 Tennyson Street
P (303)-458-5370 F (303)-458-5325

Illinois, Franklin Park 60131
9300 King Street
P (847)-678-3232 F (847)-678-0642

North Carolina, Asheville 28803
150 Sweeten Creek Road
P (828)-274-2770 F (828)-274-1534

Pennsylvania, Bridgeport 19405
Continental Business Center
Front & Ford Street STE-M11
P (610)-239-8831 F (610)-239-8832

Texas, Dallas 75227
7850 Carr Street
P (214)-275-0013 F (214)-275-0310

Texas, Houston 77087
4000 Telephone Road Unit B-16
P (713)-643-4426 F (713)-643-9206

Brunner & Lay

9300 King Street
P.O. Box 1329
Franklin Park IL 60131
Phone: (847)-678-3232
Fax: (847)-678-0642

1510 N. Old Missouri Rd.
P.O. Box 1190
Springdale AR 72764
Phone: (501)-756-0880
Fax: (501)-756-5366

Toll Free: 1-(800)-872-6899
Website: www.brunnerlay.com
E-mail: info@brunnerlay.com