

TABLE OF CONTENTS

AIR-POWERED VIBRATORS

Applications.....	1
-------------------	---

AIR-PISTON VIBRATORS

General Description	2
VMSAC&VMRAC	3
VMS & VMR	4
SI.....	5
VMRR & VMBB	6
SI-RR & Railroad Cart.....	7
SA-EP, SAM, & ACM.....	8
UH & VG	9
LA, CBS, & C-1175	10
FLSH, T, V, & CIR.....	11
VM-25, VMRAC-EP, & PMA.....	12

BALL VIBRATORS

General Description	13
VBB, VBC, & VBD.....	14
VBM, VBM-P, & 110 Drum Vibrator.....	15
E, F, & U	16,17

ACCESSORIES AND REPAIR SERVICES

General Description	18
---------------------------	----

Applications

Page number	3	4	5	6	6	7	8	8	9	9	12	12	12	10	10	10	11	11	11	11	11	13
Model	MSHC	VMS	SI	VMPR	VMBB	SI-RR	SA-EP	SAM	ACM	UHM	VGVM	VM-25	EP	PMA	LA	CBS	C-1175	CIR	FLSH	T	>	BALL
CHEMICAL																						
Hoppers & Bins	●	●	●				●	●	●	●		●		●								●
Chutes & Pipes	●	●	●				●	●	●													●
Rail Cars				●	●	●																
Precipitators	●	●	●											●								
Screening	●	●					●					●	●							●		●
Filters	●	●	●				●	●	●				●	●						●		
FOUNDRY																						
Rail Cars				●	●	●																
Molding Machines																●	●					●
Core Machines																●	●					
Match Plates							●	●	●						●							●
Shake-out			●										●						●	●	●	
Sand Bins	●	●	●				●			●				●								●
Roll-Over Machines																		●				
CONCRETE																						
Hoppers & Bins	●	●	●				●	●	●	●				●								●
Chutes	●	●	●				●	●	●													●
Rail Cars				●	●	●																
Forms				●	●		●			●	●											●
FOOD																						
Hoppers & Bins	●	●	●				●	●	●	●				●								●
Chutes & Pipes	●	●	●				●	●	●	●												●
Rail Cars				●	●	●																
Screening	●	●					●					●	●									●
Spray Dryers	●	●	●				●	●	●	●												
WOOD & PA-																						
Hoppers & Bins	●	●	●				●	●	●	●				●								●
Rail Cars				●	●	●																
Precipitators	●	●	●											●								
Dust Collectors	●	●	●				●	●	●	●				●								
MINING																						
Hoppers & Bins	●	●	●				●	●	●	●				●								●
Chutes	●	●	●				●	●	●	●												●
Rail Cars				●	●	●																
Screening	●	●					●					●	●							●		●
Forms				●			●			●	●											
AUTOMOTIVE																						
Supply Hoppers	●	●	●				●	●	●	●				●								●
Tote Bins	●	●											●									
Parts Tracks							●	●	●			●										●
STEEL																						
Hoppers & Bins	●	●	●				●	●	●	●				●								●
Rail Cars				●	●	●																
Precipitators	●	●	●											●								
Refractory Lining										●	●											

GENERAL DESCRIPTION OF AIR-POWERED VIBRATORS

The **Cleveland Vibrator** Company offers a wide range of air-piston vibrators to promote the flow of dry, bulk solids material. These vibrators are powered by compressed air which should be dry and lubricated. They produce a linear force which has proven to be most reliable as a material flow aid.

Air-piston vibrators are most commonly used as **discharge flow aids on bins, hoppers and chutes**. They also provide more specific services primarily in the chemical, foundry and concrete industries. (Please refer to the Application Chart to locate the recommended vibrator for your specific application.)

Additionally, air-piston vibrators have been used successfully as **drives for vibratory equipment**. This would include vibrating **feeders, screeners, conveyors, tables and bowl feeders**, as well as other vibratory equipment. Their ease of attachment and linear force output also make them useful for a wide variety of other applications.

The vibrator bodies are made from either alloy steel or ductile iron. The smaller piston vibrators have alloy steel bodies and the larger units have ductile iron bodies. The bodies are machined and honed to within precision tolerances and then fitted with a piston. **Many of the ductile iron bodies incorporate**

enough additional material to allow them to be re-bored up to two times and fitted with oversized pistons. These rebuilt vibrators are typically sixty percent of the price of a new unit, and carry a new warranty.

It is imperative that the compressed air be dry and lubricated. The lubricant should be injected into the air stream to create a fog or mist. This will maintain an oil film on the piston and the bore of the body.

Where lubrication is not possible or extreme temperatures prohibit the use of oil, we can provide **vibrators with a special coating**. The coating procedure enables the efficient running of the piston vibrator without lubrication. This space-age coating has also been found to extend the life of the vibrator. And, unlike other coatings, our special coating allows the user to operate the vibrators using lubricated air without causing the piston to stick in the body.

Our pistons are made from alloy steel, and are manufactured on automated CNC machines to insure precise tolerances. The machined pistons are then hardened using a unique process we refer to as NitroFusion. This new process replaces case hardening and chrome plating without harming the environment. NitroFusion has proven to be superior to chrome plating in the following areas:

- Longer Wear Resistance
- Better Corrosion Resistance
- No Distortion
- Improved Fatigue Strength
- Excellent Sliding Properties

Air-piston vibrators require a quick-acting valve to start and stop. The valve can be a manual type, activated by hand, knee or foot. Or it can be an electrically controlled solenoid type activated by a switch or push button. The valve should be located within ten feet of the vibrator(s).

The air-piston vibrator should be controlled by means of an FRL (Filter, Regulator and Lubricator). The filter helps keep the air clean and dry. The regulator allows adjustment of the air pressure to vary the force and frequency of vibration. The lubricator injects lubricant for the moving parts. (A lubricator is not required for air-piston vibrators in which the vibrator is specially coated as described earlier.)

Air-piston vibrators are recommended for use in hazardous areas, and are ideal for atmospheres containing explosive dust, vapor, or gas. A proper explosion-proof valve to ensure safe operation in hazardous areas must activate the vibrators.

VMSAC & VMRAC

VIBRA-MIGHT AIR-CUSHIONED VIBRATOR

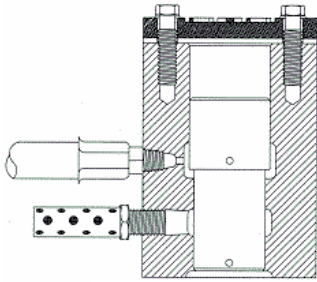

CUT AWAY

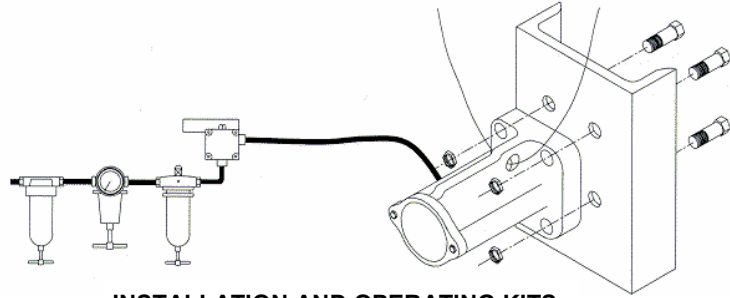

INSTALLATION AND OPERATING KITS

The VMSAC and VMRAC piston is cushioned on a pad of air at both ends of the stroke to ensure no metal to metal contact. The vibrator has a single-threaded exhaust port with exhaust muffler to reduce noise level. Additionally, the double-diameter piston guarantees the vibrator can start at any mounting angle with minimum air pressure and without the use of a piston return spring.

VMSAC has a one-piece, rugged ductile iron cylinder housing which decreases the weight of the vibrator. The body is cast with a provision for attachment of a safety cable. The unit is supplied complete with heavy-duty mounting fasteners and a gasket.

The information contained in the chart to the right is the result of many years of experience. It is a reasonably accurate approach to giving you quick information regarding vibrator sizing on a hopper, bin, or chute.

SIZING CHARTS FOR BINS AND HOPPERS		
Bin Capacity lbs./kg	Approx. Skin Thickness of Bin in/mm	VMSAC Vibrator Size
200 91	1/8 3.2	1125
700 317	1/8 3.2	1150
ton/m. ton		
1 0.9	1/8-3/16 3.2-4.8	1200
3 2.7	3/16-1/4 4.8-6.4	1300
20 18	5/16-3/8 7.9-9.5	1350
50 45	3/8 9.5	1400
100 90	3/8 9.5-12.7	1500

VMSAC

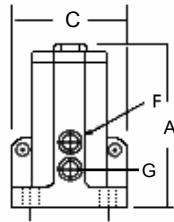
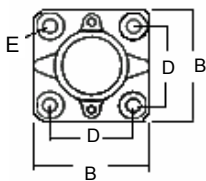

VMRAC

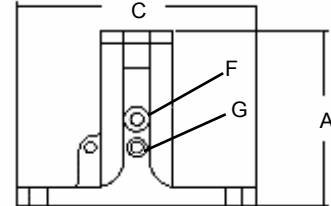
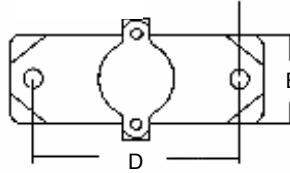

VMSAC ● VMRAC		Coated vibrators for non-lubricated applications are available.									
MODEL	PISTON DIA. in/cm	A in/cm	B in/cm	C in/cm	D in/cm	E in/cm	F in/cm	G in/cm	WT. lbs/kg	AIR CNSMP. scfm/ lmp (lmp=liter per min) @ 60 psig 4.1 bar	FREQUENCY* (vibrations per min.) @ 60 psig 4.1 bar
VMRAC 1125	1-1/4 3.2	5-7/16 13.8	3 7.6	5-3/4 14.6	4-1/2 11.4	1/2 1.3	1/4 .64	1/4 .64	6 2.7	8.0 249	3050
VMRAC 1200	2 5.1	7 17.8	3-1/4 8.3	9-3/16 23.3	7-1/2 19.1	3/4 1.9	1/4 .64	3/8 1.0	14 6.4	9 255	2700
VMRAC 1300	3 7.6	9-13/16 23.3	6 15.24	10-1/2 20.66	3-1/4 X 7-3/4 9.52 X 19.68	7/8 2.25	3/8 .95	1/2 1.3	28 13	21.5 609	2300
VMRAC 1350	3-1/2 8.9	11-5/16 28.73	6 15.25	10-1/2 20.66	3-1/4 X 7-3/4 9.52 X 19.68	7/8 2.25	1/2 1.3	1/2 1.3	34 15	23 651	1900
VMSAC 1125	1-1/4 3.2	4-11/16 11.9	3 7.6	3 7.6	2 5.1	3/8 1.0	1/4 .64	1/4 .64	6 2.7	8.0 205	3050
VMSAC 1150	1 1/2 3.8	5-13/16 14.8	4-1/8 10.5	4-1/8 10.5	3 7.6	5/8 1.6	1/4 .64	3/8 1.0	13 5.9	9.0 170	2700
VMSAC 1200	2 5.1	6-9/16 16.7	4-3/8 11.1	4-3/8 11.1	3 7.6	5/8 1.6	1/4 .64	3/8 1.0	14 6.4	11 311	2600
VMSAC 1300	3 7.6	8-7/16 21.4	5-3/4 14.6	5-3/4 14.6	4-1/8 10.5	3/4 1.9	3/8 .95	1/2 1.3	28 13	21.5 609	2300
VMSAC 1350	3-1/2 8.9	10.0 26.8	5-3/4 14.6	5-3/4 14.6	4-1/8 10.5	3/4 1.9	1/2 1.3	1/2 1.3	34 15	23 651	1900
VMSAC 1400	4 10.2	12 30.5	8-1/2 21.6	8-1/2 21.6	6-1/4 15.9	1-1/4 3.2	1/2 1.3	3/4 1.9	99 45	29.0 821	1260
VMSAC 1500	5 12.7	17 43.2	11 27.9	11 27.9	7-7/16 18.9	1-1/4 3.2	3/4 1.9	1 2.5	235 107	66 1869	920

*Frequency data obtained through testing under a no-load condition. Frequency will decline as load is increased.
NOTE: VMSAC also available in 1700 and 1900 sizes. Consult factory for details.

VMS & VMR

METALLIC-IMPACT VIBRATOR

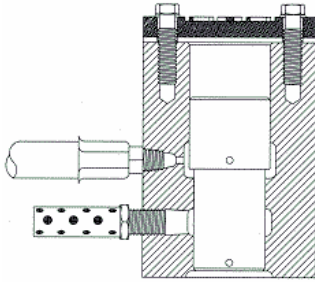

CUT AWAY

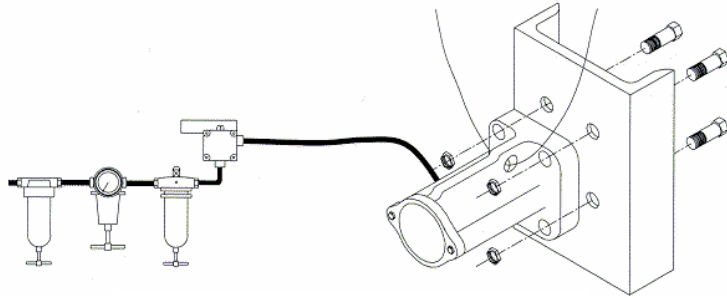

INSTALLATION AND OPERATING KITS

The VMS piston impacts directly against a channel mounting plate. The VMR piston impacts against part of the vibrator's base. A single exhaust port with port protector, prevents the entrance of dirt into the vibrator's exhaust cavity, prolonging the life of the vibrator. And, the double-diameter piston guarantees starting at any mounting angle with minimum air pressure, and without the use of a piston return spring.

Like VMSAC, VMS has a one-piece, rugged ductile iron cylinder housing which decreases the weight of the vibrator. The body is cast with a provision for attachment of a safety cable. Also, VMS is easily installed. It may be mounted on any appropriately sized mounting channel (available for sale), and it comes complete with heavy-duty mounting fasteners and a gasket.

The information contained in the chart to the right is the result of many years of experience. It is a reasonably accurate approach to giving you quick information regarding vibrator sizing on a hopper, bin, or chute.

SIZING CHARTS FOR BINS AND HOPPERS		
Bin Capacity lbs./kg	Approx. Skin Thickness of Bin in/mm	VMS Vibrator Size
700 91	1/8 3.2	1125
ton/m. ton		
1 0.9	1/8-3/16 3.2-4.8	1150
3 2.7	3/16-1/4 4.8-6.4	1200
20 18	5/16-3/8 7.9-9.5	1300
50 45	3/8 9.5	1350
100 90	3/8 9.5-12.7	1400
100 and up 90	3/4-1 19.1-25.4	1500

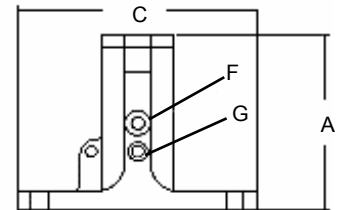
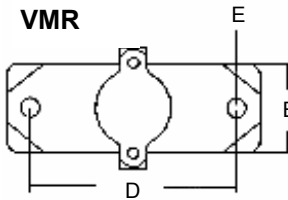
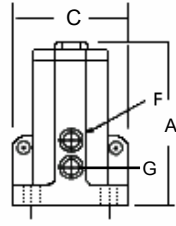
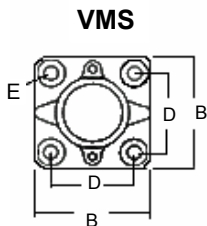

VMS ● VMR		Coated vibrators for non-lubricated applications are available.									
MODEL	PISTON DIA. in/cm	A in/cm	B in/cm	C in/cm	D in/cm	E in/cm	F in/cm	G in/cm	WT. lbs/kg	AIR CNSMP. scfm/lmp (lmp=liter per min) @ 60 psig 4.1 bar	FREQUENCY* (vibrations per min.) @ 60 psig 4.1 bar
VMR 1125	1-1/4 3.2	5-7/16 13.8	3 7.6	5-3/4 14.6	4-1/2 11.4	1/2 1.3	1/4 .64	1/4 .64	6 2.7	7 198	4640
VMR 1200	2 5.1	7 17.8	3-1/4 8.3	9-3/16 23.3	7-1/2 19.1	3/4 1.9	1/4 .64	3/8 1.0	14 6.4	7.2 204	4500
VMR 1300	3 7.6	9-13/16 23.3	6 15.24	10-1/2 20.66	3-1/4 X 7-3/4 9.52 X 19.68	7/8 2.25	3/8 .95	1/2 1.3	28 13	21.5 609	3350
VMR 1350	3-1/2 8.9	11-5/16 28.73	6 15.25	10-1/2 20.66	3-1/4 X 7-3/4 9.52 X 19.68	7/8 2.25	1/2 1.3	1/2 1.3	34 15	21 595	2400
VMS 1125	1-1/4 3.2	4-11/16 11.9	3 7.6	3 7.6	2 5.1	3/8 1.0	1/4 .64	1/4 .64	6 2.7	7.4 210	4640
VMS 1150	1 1/2 3.8	5-13/16 14.8	4-1/8 10.5	4-1/8 10.5	3 7.6	5/8 1.6	1/4 .64	3/8 1.0	13 5.9	7.4 210	4000
VMS 1200	2 5.1	6-9/16 16.7	4-3/8 11.1	4-3/8 11.1	3 7.6	5/8 1.6	1/4 .64	3/8 1.0	14 6.4	10 311	4500
VMS 1300	3 7.6	8-7/16 21.4	5-3/4 14.6	5-3/4 14.6	4-1/8 10.5	3/4 1.9	3/8 .95	1/2 1.3	28 13	21.5 609	3350
VMS 1350	3-1/2 8.9	10.0 26.8	5-3/4 14.6	5-3/4 14.6	4-1/8 10.5	3/4 1.9	1/2 1.3	1/2 1.3	34 15	21 595	2400
VMS 1400	4 10.2	12 30.5	8-1/2 21.6	8-1/2 21.6	6-1/4 15.9	1-1/4 3.2	1/2 1.3	3/4 1.9	99 45	38 1076	2100
VMS 1500	5 12.7	17 43.2	11 27.9	11 27.9	7-7/16 18.9	1-1/4 3.2	3/4 1.9	1 2.5	235 107	60 1700	1150

*Frequency data obtained through testing under a no-load condition. Frequency will decline as load is increased.

NOTE: VMS also available in 1700 and 1900 sizes. Consult factory for details.

SINGLE IMPACTOR FOR PERMANENT INSTALLATION

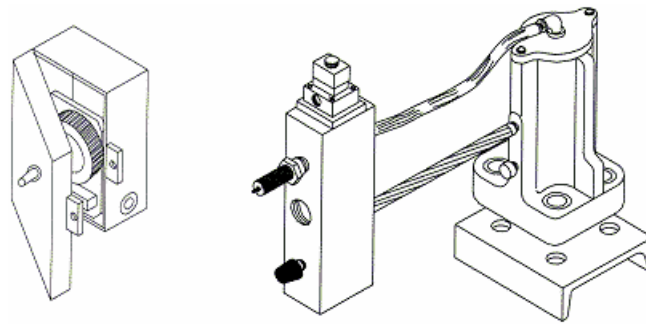

INSTALLATION AND OPERATING KITS

The single impactor delivers one impact at a maximum frequency of once every three seconds through a five-port spool valve. A timer is used to vary the cycle required. Single impactors are most effective for sticky materials because they are less likely than continuous vibration to cause packing in hoppers.

Low maintenance is guaranteed by a combination of a springless design and only one moving part. The single impactor makes less noise and consumes less air than most air and electric vibrators because there is no continuous blast of exhausting air.

Like VMSAC and VMS, the SI has a one-piece, rugged ductile iron

cylinder housing which decreases the weight of the vibrator. It may be mounted on any appropriately sized mounting channel, and comes complete with heavy-duty mounting fasteners and a gasket.

These vibrators are internally coated for enhanced performance.

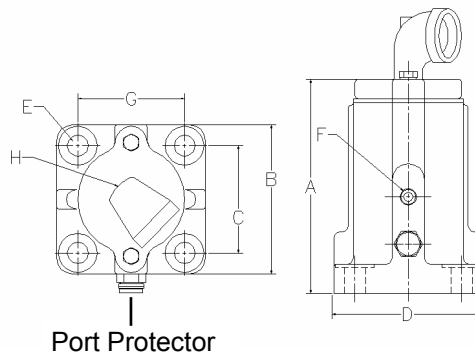

Port Protector

SI													ENERGY PER IMPACT				
MODEL	PISTON DIA. in/cm	A in/cm	B in/cm	C in/cm	D in/cm	E in/cm	F in/cm	G in/cm	H NPT	WT. lbs/kg	AIR CNSMP. cf/stroke liter/stroke @ 80 psig 5.4 bar	ft lbs/cm kg psig/bar					
												@ 20 @ 1.4	@ 40 @ 2.7	@ 60 @ 4.1	@ 80 @ 5.4	@ 100 @ 6.8	
1125	1-1/4	6-3/8	3	2	3	3/8	1/4	2	3/8	8	.010	3	6	8	11	14	
	3.2	16.2	7.6	5.1	7.6	1.3	0.6	5.1	1.0	3.6	0.3	41	83	111	152	194	
1200	2	6-1/2	4-1/2	3	4-1/2	5/8	1/4	3	1/2	18	.020	6	12	19	25	31	
	5.1	16.5	11.4	7.6	11.4	1.6	0.6	7.6	1.3	18.2	0.6	83	166	263	346	429	
1300	3	8-5/16	5-3/4	4-1/8	5-3/4	3/4	3/8	4-1/8	1/2	32	.084	21	43	64	86	108	
	7.6	21.1	14.6	10.5	14.6	1.9	1.0	10.5	1.3	15	2.4	290	595	885	1,189	1,493	
1350	3-1/2	10	6	4-1/8	6	3/4	1/2	4-1/8	3/4	39	.120	43	86	129	172	215	
	8.9	25.4	15.2	10.5	15.2	1.9	1.3	10.5	1.9	18	3.4	595	489	1,784	2,378	2,973	
1400	4	11-7/8	8-5/8	6-1/4	8-5/8	1-1/4	1/2	6-1/4	3/4	109	.242	88	177	265	354	442	
	10.2	30.2	21.9	15.9	21.9	3.2	1.3	15.9	1.9	49	6.9	1,217	2,447	3,664	4,894	6,111	
1500	5	16-3/8	10-1/2	7-7/16	10-1/2	1-1/4	3/4	7-7/16	1	253	.526	197	394	592	789	986	
	12.7	41.6	26.7	18.9	26.7	3.2	1.9	18.9	2.5	115	14.9	2,724	4,065	5,420	10,909	13,632	
1700	7	19-3/4	13-1/2	8-1/2	16	1-1/2	1	13	1-1/4	550	1.078	356	712	1,069	1,425	1,781	
	17.8	50.2	34.3	21.6	40.6	3.8	2.5	33.0	3.2	249	30.5	4,922	9,844	14,780	19,702	24,624	
1900	9	19-3/4	15-1/2	8-1/2	16	1-1/2	1-1/4	13	1-1/2	700	1.658	568	1,136	1,704	2,277	2,840	
	22.9	50.2	39.4	21.6	40.6	3.8	3.2	33.0	3.8	318	47.0	7,853	1,571	23,560	31,482	39,266	

VMRR & VMBB

METALLIC-IMPACT OR AIR-CUSHIONED

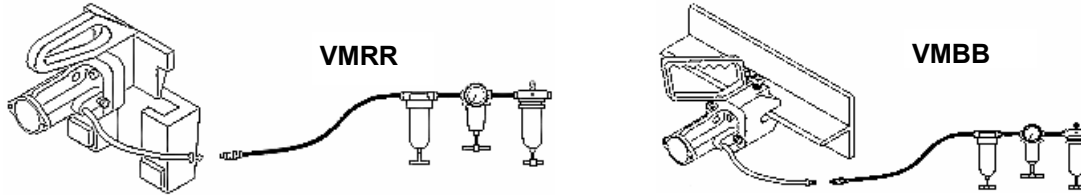

INSTALLATION AND OPERATING KITS

VMRR and VMBB air-powered vibrators eliminate the hazards connected with climbing around railroad cars and poking their contents to keep the materials flowing freely. In addition, their use can reduce unloading time by as much as 30%. (These vibrators can be handled by one man.)

The VMRR for railroad cars is designed for use with covered hopper cars that are equipped with female brackets that are available for sale see below). The VMBB for railroad cars is used on all other types of covered hopper railroad cars, as well as portable installations on large bins. These units

utilize either the VMS (impact) or VMSAC (air-cushion) vibrator with either the male wedge (VMRR) or bolt-bite (VMBB) mounting head.

Specify VMRR-AC or VMBB-AC when quiet operating, air-cushioned vibrators are required.

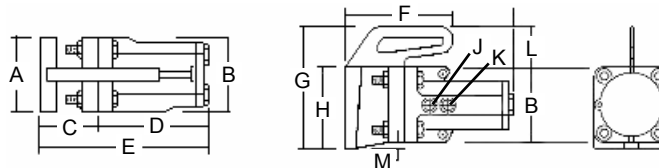

VMRR		Coated vibrators for non-lubricated applications are available.														
MODEL	PISTON DIA. in/cm	A in/cm	B in/cm	C in/cm	D in/cm	E in/cm	F in/cm	G in/cm	H in/cm	J in/cm	K in/cm	L in/cm	M in/cm	WT. lbs/kg	AIR CNSMP scfm/lpm (lpm=liter per min) @ 60 psig 4.1 bar	FREQUENCY* (vibrations per min.) @ 60 psig 4.1 bar
1200	2 5.1	5-1/2 14.0	4-1/2 11.4	3-3/4 9.5	6-1/2 16.5	10-1/4 25.9	7 17.8	7-1/2 19.1	5 12.7	3/8 1.0	1/4 0.6	2-1/2 6.4	-	33 14.9	7.2 204	4500
1300	3 7.6	6 15.2	5-3/4 14.6	5-1/4 13.3	8-5/16 21.1	13-9/16 34.4	7 17.8	11-1/2 29.2	7 17.8	1/2 1.3	3/8 1.0	4-3/4 12.1	1 2.5	83 38	18.5 524	3350
1350	3-1/2 8.9	6 15.2	6 15.2	5-1/4 13.3	10 25.4	15-1/4 38.7	7 17.8	11-1/2 29.2	7 17.8	1/2 1.3	1/2 1.3	4-1/2 11.4	1 2.5	93 42	21 595	2400
1400	4 10.2	6 15.2	8-5/8 21.9	6 15.2	11-7/8 30.2	17-7/8 45.4	** **	** **	7 17.8	3/4 1.9	1/2 1.3	** **	-	165 75	25.0 708	2100

*Frequency data obtained through testing under a no-load condition. Frequency will decline as load is increased.

**Handles are extension of top two bolts. Dimension confined by BxBxE.

VMBB TECHNICAL DATA

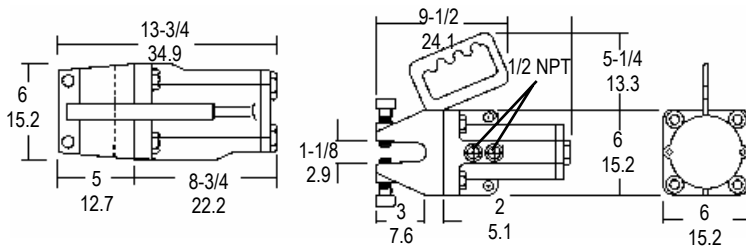

WT. lbs/kg	AIR CONSUMP. scfm/lpm (lpm=liter per min) @60 psig 4.1 bar	Frequency (vibrations per minute) @60 psig 4.1 bar
90 41	17.5 496	2400

The VMBB is available in two sizes, the 1300 and 1350. Data shown is for the more popular 1350 size (dimensions are in in/cm).

LSRR BRACKET

LSRR-FL are cast steel female brackets that are standard equipment on covered hopper railroad cars. They can be welded or bolted to a structure. LSRR-FS was designed for use with the 2" (1200) vibrator only. It is ideal for portable bins and hoppers.

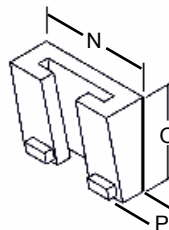

	LSRR-FL in/cm	LSRR-FS in/cm
N	7-3/4 19.7	7 17.8
O	7 17.8	4-3/4 12.1
P	3-3/8 8.6	2-1/2 6.4
WT. lb/kg	25/11	12/5

SI-RR RAILROAD CART

SINGLE IMPACTOR FOR RAILROAD CAR UNLOADING AND PORTABLE APPLICATIONS

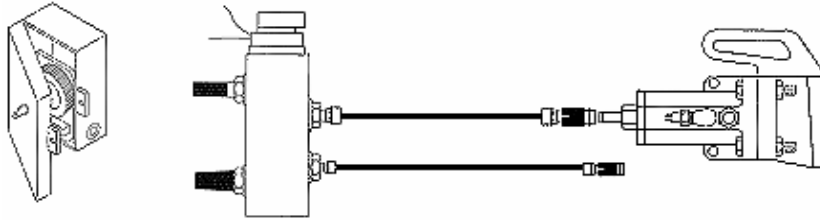

INSTALLATION AND OPERATING KITS

The SI-RR delivers one impact every three seconds. (Other time cycles are available.) The unit produces less noise and uses less air than the normal air vibrator. And SI-RR offers the same portable features as the VMRR.

Low maintenance is guaranteed by a combination of a springless design and only one moving part. The SI-RR makes less noise and consumes less air than most air and electric vibrators because there is no continuous

blast of exhausting air.

These vibrators are internally coated for enhanced performance.

SI-RR is easily installed, and comes complete with all necessary components for proper operation.

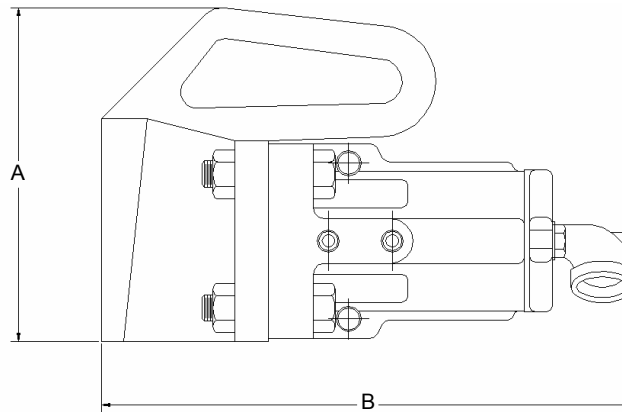

SI-RR					
MODEL	WT lbs/kg	A in/cm	B in/cm	ENERGY PER IMPACT ft lbs/cm kg @100 psi/ 6.8 bar	MAX. AIR CNSMP/ IMPACT cf/stroke liter/stroke @80 psi/5.4 bar
1200	25	7-1/2	10-1/4	31	.020
	11	19.1	26.0	429	0.6
1300	83	11-1/2	13-9/16	108	.084
	38	29.2	34.4	1,493	2.4
1350	93	11-1/2	15-1/4	215	.120
	42	29.2	38.7	2,973	3.4
1400	165	10-1/2	17-7/8	442	.242
	75	26.7	45.4	6,111	6.9

RAILROAD CART

The CVC railroad cart is designed for use with the models 1300, 1350 and 1400 VMRR or SI-RR vibrators. The cart reduces operator fatigue and back injuries caused by lifting vibrators. The lever action requires minimal efforts to raise and lower into

female brackets on rail cars. The 10" pneumatic tires allow for easy maneuvering over rough and uneven terrain. Overall dimensions 24" (61 cm) wide by 76" (193 cm) long by 34-9/16" (88 cm) high.

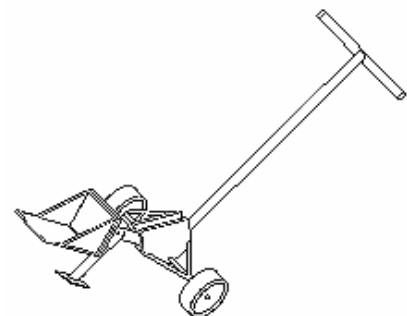

SA-EP, ACM, & SAM

METALLIC-IMPACT AIR VIBRATOR

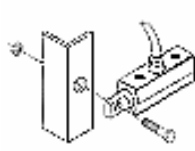

SA-EP

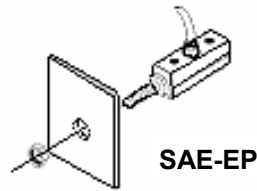

SAE-EP

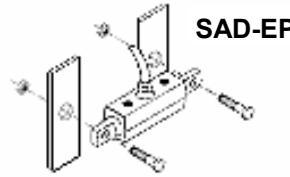

SAD-EP

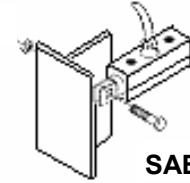

SAB-EP

Linear vibration force makes the Model SA-EP the most powerful, continuous-duty vibrator for its size. It is especially effective for match plates and shell core machine applications in the foundry industry. The SA-EP is also

useful in eliminating bridging and plugging in small bins, hoppers and chutes. A variety of mounting heads are available to allow quick and easy installation for countless other applications where a small vibrator is

desired.

Full porting insures quick starts, full power and smooth operation. Exhaust protection is provided to prevent contamination from entering the body through the exhaust holes.

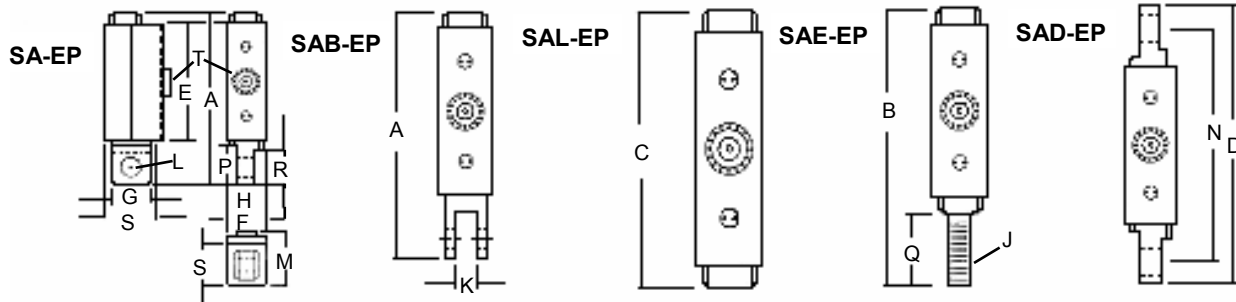

SA-EP		Coated vibrators for non-lubricated applications are available.																					
PISTON DIA. in/cm	A in/cm	B in/cm	C in/cm	D in/cm	E in/cm	F in/cm	G in/cm	H in/cm	J in/cm	K in/cm	L in/cm	M in/cm	N in/cm	P in/cm	Q in/cm	R in/cm	S in/cm	T in/cm	WT. lbs/kg	air cnsmp. scfm/lpm @60 psig 4.1 bar	frequency* (vib per min) @60 psig 4.1 bar		
1/2 1.3	5-3/16 13.2	5-3/4 14.6	4-1/2 11.4	5-7/8 14.9	3-3/4 9.5	1.0 2.5	3/4 1.9	5/16 0.8	1/2-13nc 0.9	11/32 0.9	5/16 0.8	1-13/32 3.6	5-1/4 13.3	13/16 2.1	1-1/4 3.2	9/16 1.4	7/8 2.2	1/8 0.3	1.0 0.5	3.8 108	16,000		
5/8 1.6	5-3/8 13.7	5-3/4 14.6	4-1/2 11.4	6-1/4 15.9	3-3/4 9.5	1-1/8 2.9	7/8 2.2	13/32 1.0	1/2-13nc 1.0	3/8 1.0	3/8 1.0	1-17/32 3.9	5-5/16 13.5	1.0 2.5	1-1/4 3.2	3/4 1.9	1.0 2.5	1/4 0.6	1-1/4 0.6	4.0 113	14,100		
3/4 1.9	5-3/8 13.7	5-3/4 14.6	4-1/2 11.4	6-1/4 15.9	3-3/4 9.5	1-5/16 3.3	1 2.5	13/32 1.0	1/2-13nc 1.0	7/16 1.1	3/8 1.0	1-23/32 4.4	5-3/8 13.7	1.0 2.5	1-1/4 3.2	3/4 1.9	1-3/16 3.0	1/4 0.6	1-3/4 0.8	5 142	12,700		
1 2.5	5-5/16 15.1	6-5/16 16.0	4-13/16 12.2	7-1/16 17.9	3-15/16 10.0	1-5/8 4.1	1-1/4 3.2	9/16 1.4	5/8-11nc 1.3	1/2 1.3	1/2 1.3	2-1/32 5.2	5-31/32 15.2	1-3/16 3.0	1-1/2 3.8	15/16 2.4	1-1/2 3.8	1/4 0.6	3-1/2 1.6	5 142	11,000		
1-1/4 3.2	7-5/8 19.4	9-1/8 23.2	5-7/8 14.9	9-3/8 23.8	5-3/8 13.7	n/a	1-5/8 4.1	11/16 1.7	3/4-10nc 1.3	1/2 1.3	1/2 1.3	2-3/4 7.0	8.0 20.3	1-7/16 3.7	1-3/8 3.5	1-7/16 3.7	2-3/16 5.6	1/4 0.6	6-3/4 3.1	6.0 170	7,600		

AIR-CUSHIONED PISTON VIBRATORS

SAM and ACM air-cushioned piston vibrators provide powerful yet quiet vibration. Quiet because the piston is cushioned on a pad of air at the end of each stroke ensuring no metal to metal contact. Standard

features include a built-in exhaust manifold, which captures the exhausting air and directs it through a muffler. SAM and ACM vibrators keep materials moving quickly and efficiently in small hoppers, bins, chutes, tracks,

and test devices. For foundry applications, they are a quiet alternative to model SA-EP on match plates and for shell core machines.

D (ACM has end inlet)

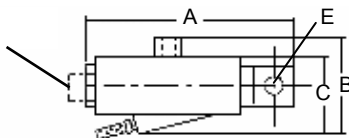

1-1/4" SAM has exhaust manifold at right angles to inlet

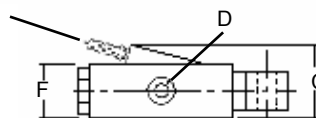

ACM • SAM		Coated vibrators for non-lubricated applications are available.									
MODEL	PISTON DIA. in/cm	A in/cm	B in/cm	C in/cm	D in/cm	E in/cm	F in/cm	WT lb/kg	AIR CNSMP. scfm/lpm @80 psig 5.4 bar	FREQUENCY* (vib per min) @80 psig /5.4 bar	
3/4" ACM	3/4 1.9	5-3/4 14.6	n/a	1-15/16 4.9	1/4 0.6	3/8 1.0	1-3/16 3.0	1-1/2 0.7	2.8 79.3	3550	
1" SAM	1 2.5	5-7/8 14.9	2-3/4 7.0	2-1/4 5.7	1/4 0.6	1/2 1.3	1-1/2 3.8	3-1/2 1.6	3.7 105	3900	
1-1/4" SAM	1-1/4 3.2	7-3/4 19.7	2-5/8 6.7	2-5/8 6.7	1/4 0.6	1/2 1.3	2 5.1	7 3.2	7 198	3200	

UH, UHVM, & VGVM

AIR-POWERED PORTABLE VIBRATORS

The UH and UHVM air-powered portable vibrators can be utilized on small bins, hoppers or chutes--wherever a permanent mounted vibrator installation would impede production.

The UH and UHVM vibrators are also ideal for use on concrete forms where complete portability is desired. These rugged vibrators have adjustable high frequency vibration for maximum efficiency. When the job becomes too big for the 1-1/4" models, the 2" models take over, and can be used with the same mounting bracket.

The vibrators are equipped with an alloy steel stud mounting head which is quickly and easily inserted into the sleeve-type female bracket. Several brackets can be welded in locations where vibration is required allowing the vibrators to be moved from bracket to bracket.

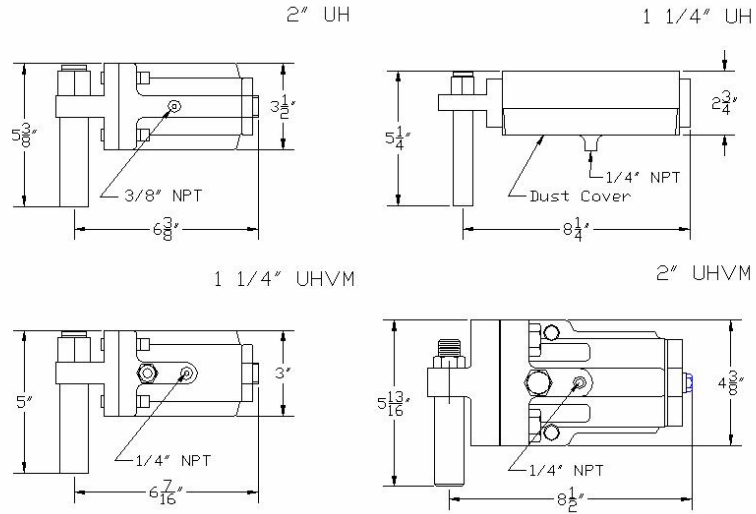

UH	<i>Coated vibrators for non-lubricated applications are available.</i>			
MODEL	PISTON DIA. in/cm	WT lbs/kg	AIR CNSMP. scfm/lpm (lpm=liters per min.) @60 psig 4.1 bar	FREQUENCY* (vibrations per min.) @60 psig 4.1 bar
UH 1-1/4	1-1/4	8 3.6	6.3 188	8000
UH 2	2	14 6.4	9.6 272	4500
UHVM 1-1/4	1-1/4 3.2	8 3.6	7.2 204	4640
UHVM 2	2 5.1	23 10.2	7.2 204	4500

Specify UHVM-AC when quiet-operation air-cushioned vibration is required.

**Frequency data obtained through testing under a no-load condition. Frequency will decline as load is increased.*

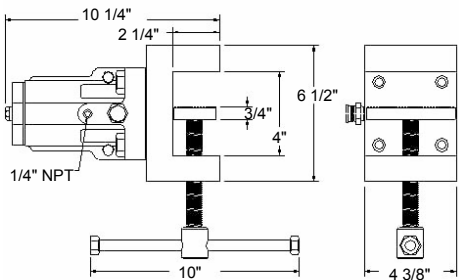

Lightweight and portable, the VGVM air-powered vibrator is easy to handle and popular with operators. On concrete forms, the VGVM attaches quickly to any structural member. The serrated jaws bite firmly on metal or wood. Form time and wasted man hours are reduced. In foundry operations, the VGVM increases core production, gives faster and cleaner draws, and prolongs core box life without core distortion. Frequency and amplitude are controlled by adjusting the air supply. Maintenance is held to a minimum because the piston is the only moving part.

VGVM	<i>Coated vibrators for non-lubricated applications are available.</i>			
MODEL	PISTON DIA. in/cm	WT lbs/kg	AIR CNSMP. scfm/lpm @60 psig 4.1 bar	FREQUENCY* (vib per min.) @60 psig 4.1 bar
2	2 5.1	33 14.9	7.2 204	4500

Specify VGVM-AC when quiet-operation air-cushioned vibration is required.

**Frequency data obtained through testing under a no-load condition. Frequency will decline as load is increased.*

LA, CBS, & C-1175

SPRINGLESS DOUBLE-IMPACT MATCH-PLATE VIBRATOR

The LA eliminates maintenance worries and down time that results from vibrator spring breakage. LA vibrator design incorporates an end

intake connection with built-in swivel action, and patented features provide trouble-free operation. This vibrator is engineered to give long, uninterrupted

service with lower operating costs. The LA is furnished with "el" type 3/8" (1.0 cm) hose fitting.

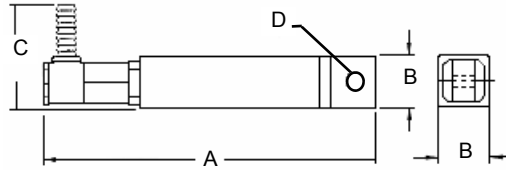

LA	<i>Coated vibrators for non-lubricated applications are available.</i>						
PISTON DIA. in/cm	A in/cm	B in/cm	C in/cm	D in/cm	air cnsmp. scfm/lpm @60 psig 4.1 bar	frequency* (vib per min) @60 psig 4.1 bar	WT. lbs/kg
5/8 1.6	7 9/16 19.21	7/8 2.22	2-1/8 5.4	3/8 1.0	3.8 108	14,100	1.5 0.7
3/4 1.9	7 1/16 17.84	1.0 2.54	2-3/16 5.56	3/8 1.0	5.4 153	13,600	2 0.9
1.0 2.5	8 1/8 20.64	1-1/2 3.8	2-3/8 6.03	1/2 1.3	5.8 164	11,700	3 1.4

HEAVY-DUTY MOLDING & CORE MACHINE VIBRATORS

These rugged, powerful foundry-machine vibrators help all makes of molding and core machines operate at peak performance with an absolute minimum of maintenance.

C-1175 is intended for heavy-duty operations and features a springless piston for positive starting and low maintenance. CBS models are intended for use on light, dry molding

and core machines. *These vibrators are internally coated for enhanced performance!*

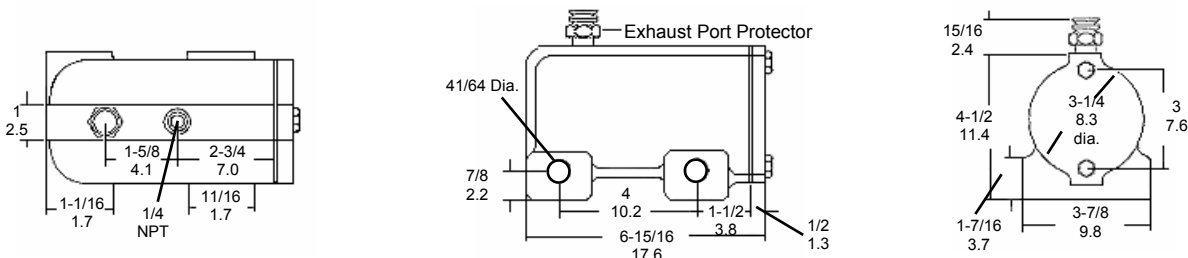

C-1175		AIR CNSMP. - scfm/lpm (lpm=liters per min)				FREQUENCY* (vib per min)				WT lbs/kg
VIBRATOR TYPE	PISTON DIA. in/cm	@20 psig 1.4 bar	@40 psig 2.7 bar	@60 psig 4.1 bar	@80 psig 5.4 bar	@20 psig 1.4 bar	@40 psig 2.7 bar	@60 psig 4.1 bar	@80 psig 5.4 bar	
metallic impact	1.75	2.7	7.2	9.25	15.8	1,800	2,225	3,000	3,300	17.0
air cushioned	4.4	76	204	262	447	1,620	2,000	2,700	2,900	7.7
air cushioned	1.75	3.0	8.0	11.0	16	1,620	2,000	2,700	2,900	17.0
air cushioned	4.4	85	227	312	453	1,620	2,000	2,700	2,900	7.7

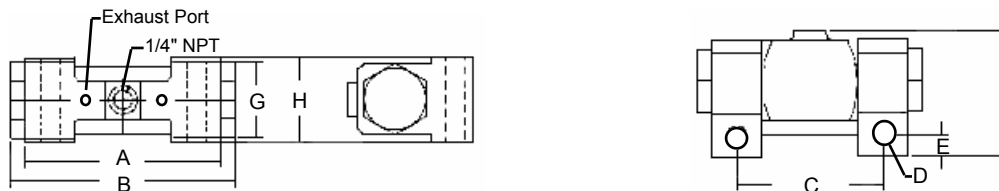

CBS		AIR CNSMP. - scfm/lpm								FREQUENCY* (vib per min)				WT. lbs/kg			
PISTON DIA. in/cm	A in/cm	B in/cm	C in/cm	D in/cm	E in/cm	F in/cm	G in/cm	H in/cm	@20 psig 1.4 bar	@40 psig 2.7 bar	@60 psig 4.1 bar	@80 psig 5.4 bar	@20 psig 1.4 bar		@40 psig 2.7 bar	@60 psig 4.1 bar	@80 psig 5.4 bar
1.0	3-15/16	4-13/16	2-7/8 or 3	33/64	31/64	2-1/2	1-1/4	1-13/16	.08	2.0	3.0	4.5	8,700	9,800	11,000	12,200	3.0
2.5	10.0	12.2	7.3 or 7.6	1.3	1.2	6.4	3.2	4.6	23	5.7	85	127	8,700	9,800	11,000	12,200	1.4
1-1/4	5-3/8	5-7/8	3-3/4 or 4	33/64	31/64	3-1/16	1-5/8	2-1/4	1.0	3.0	5.0	7.0	4,000	6,000	7,600	8,600	6.0
3.2	13.6	14.9	9.5 or 10.2	1.3	1.2	7.8	4.1	5.7	28	85	142	198	4,000	6,000	7,600	8,600	2.7

*Frequency data obtained through testing under a no-load condition. Frequency will decline as load is increased.

FLSH, T, V, & CIR

HOOK-TYPE DOUBLE IMPACT VIBRATOR

The heavy-duty FLSH is ideal for cleaning out large flasks and cores. It is double fast, since the piston strikes both ends of the vibrator assembly. An optional bumper is available.

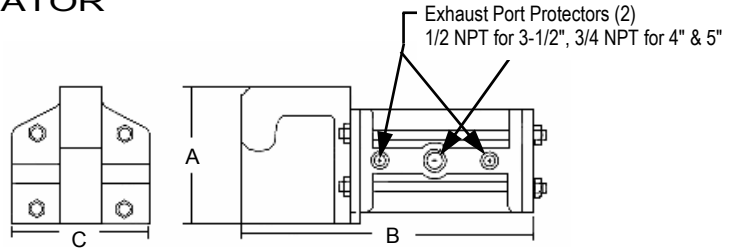

FLSH	<i>Coated vibrators for non-lubricated applications are available.</i>						
PISTON DIA. in/cm	A HEIGHT in/cm	B LENGTH in/cm	C WIDTH in/cm	air cnsmp. scfm/lpm @60 psig 4.1 bar	frequency* (vib per min) @60 psig 4.1 bar	WT. lbs/kg	FLASK WT. TO: lbs/kg
3-1/2 8.9	12 30.5	19 48.3	8 20.3	30 850	2040	100 45	500 227
4 10.2	12 30.5	23 58.4	9 22.9	32 906	1850	245 111	1500 680
5 12.7	15 38.1	42 107	9 22.9	35 991	1440	350 159	over 1500 680

HEAVY-DUTY DOUBLE-IMPACT VIBRATORS

Model T vibrators are used extensively on foundry molding machines. The larger sizes are used for shake-out of flasks and

castings.

Model V is designed for heavy-duty use between the hoist hook and the item to be shaken.

Consult factory for maximum load capacities for Model V.

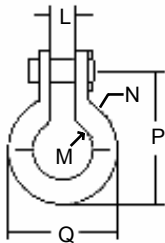

SHACKLE DATA		D	L	M	N	P	Q
VIBRATOR SIZE	SHACKLE SIZE	in/cm	in/cm	in/cm	in/cm	in/cm	in/cm
3 & 3-1/2	7/8	1.0	1-7/16	1-3/4	7/8	4-3/16	3-1/2
	2.2	2.5	3.7	4.4	2.2	10.6	8.9
4	1.0	1-1/8	1-11/16	2.0	1.0	4-3/4	4.0
	2.5	3.5	4.3	5.1	2.5	12.1	10.2
5	1-1/4	1-3/8	2-1/32	3.0	1-1/4	5-7/8	5-1/2
	3.2	3.5	5.2	7.6	3.2	14.9	14.0

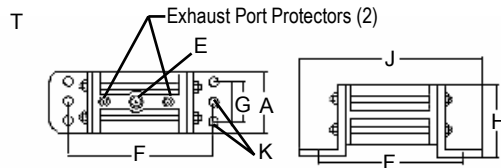
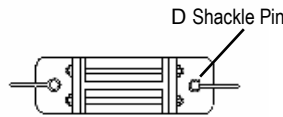
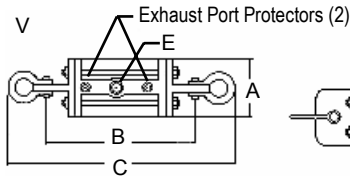

T • V	<i>Coated vibrators for non-lubricated applications are available.</i>													
PISTON DIA. in/cm	A in/cm	B in/cm	C in/cm	D in/cm	E in/cm	F in/cm	G in/cm	H in/cm	J in/cm	K in/cm	air cnsmp. scfm/lpm @ 60 psig 4.1 bar	frequency* (vib per min) @ 60 psig 4.1 bar	T WT. lbs/kg	V WT. lbs/kg
2T 5.1	4 10.2	10-9/16 26.8	16-9/16 42.1	n/a	1/4 0.6	9-3/4 24.8	n/a	4-7/8 12.4	12-1/4 31.1	5/8 1.6	13.5 382	4450	24 10.9	29 13.2
3-1/2 T&V 8.9	6 15.2	14-3/8 36.5	22-3/4 57.8	1.0 2.5	1/2 1.3	16 40.6	3-1/2 8.9	7.0 17.8	20.0 50.8	1.0 2.5	30 850	2040	100 45	90 41
4 T&V 10.2	7-3/4 19.7	16-7/8 42.9	26-3/8 67.0	1-1/8 2.9	3/4 1.9	19-1/5 49.5	3-1/2 8.9	9-1/2 24.1	22-5/8 57.5	1.0 2.5	32 906	1850	206 93	185 84
5 V 12.7	11-1/4 28.6	29-1/4 74.3	41 104	1-3/8 2.9	3/4 1.9	n/a	n/a	n/a	n/a	n/a	35 991	1440	250 113	305 138

ROLLOVER-MACHINE VIBRATORS

Model CIR is used on specialized foundry rollover machines that have a cylindrical pocket to accommodate the vibrator.

The CIR's technical data is as follows: length 5-3/4" (14.6 cm),

diameter 2-15/16" (7.5 cm), piston diameter 1-1/4" (3.2 cm), inlet port 1/4" NPT, weight 10 lbs. (4.5 kg), frequency 7600 VPM and air consumption 6.0 SCFM (170 lpm).

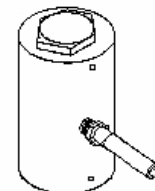

VM-25, EP, & PMA

MINIATURE AIR VIBRATOR

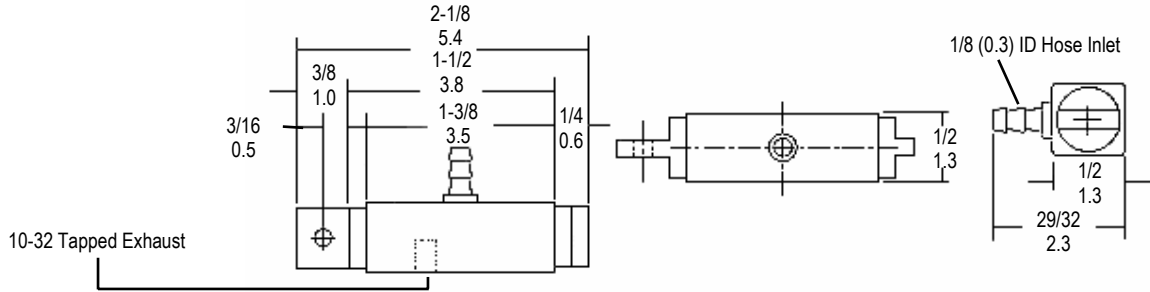

The VM-25 miniature air vibrator produces 16,000 vibrations per minute while only consuming 2.0 SCFM (57 lpm) of compressed air at 80 psig (5.4 bar).

Its size and high frequency vibration

make the VM-25 excellent for automated parts track vibration. It can also be used to promote the free flow of materials from small, thin-skinned (minimum 28 gauge) bins and hoppers up to 2 cubic feet in (57L) capacity. They can be supplied with

a muffler to prevent contamination and reduce noise level. An air-cushioned version, VMAC-25, will further reduce noise level, but at a reduced force output. Normal force output is 15 lbs.

EXTENDED-PISTON VIBRATOR

Model VMRAC-EP* vibrators feature a specially machined "extended piston". The piston extension has a threaded portion enabling it to be secured to the object receiving or transmitting vibration. This vibrator can also be used as a simple rapper with or without a

rubber bumper attached to the end of the piston extension.

These vibrators are internally coated for enhanced performance. They have the same basic design features as our Model VMRAC.

*Note: Previous style 2" piston FEP models are still available. Contact the CVC sales department for price and delivery.

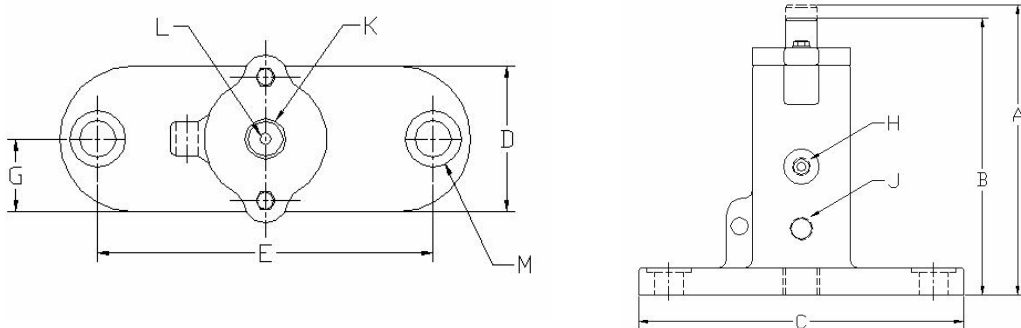

VMRAC-EP														These models can also be supplied with square bases, Model VMSAC-EP			
MODEL	PISTON DIA. in/cm	A in/cm	B in/cm	C in/cm	D in/cm	E in/cm	F in/cm	G in/cm	H in/cm	J in/cm	K in/cm	L in	M in/cm	air consmp. scfm/lpm @60 psig 4.1 bar	frequency* (vib per min) @60 psig 4.1 bar	WT. lbs/kg	
1125	1-1/4 3.2	6-3/4 17.1	6.0 15.2	5-7/8 14.9	3.0 7.6	4-1/2 11.4	n/a	1-1/2 3.8	1/4 0.6	1/4 0.6	1/2 1.3	1/4-20	11/16 1.7	7.2 204	3000	8 3.6	
1200	2.0 5.1	9-3/4 24.7	9.0 22.8	9-3/16 24.2	3-1/4 8.2	7-1/2 19.0	n/a	1-5/8 4.1	1/4 0.6	3/8 1.0	2.5	3/8-16	13/16 2.1	10 283	2700	15 6.8	
1300**	3.0 7.6	11-1/2 29.2	10.0 25.4	8-5/8 21.9	4.0 10.2	7.0 17.8	2-3/8 6.0	13/16 2.1	3/8 1.0	1/2 1.3	2.5	3/8-16	13/16 2.1	19 538	2300	32 15	

**Also available in 3" LS long-stroke FEP

RAPPER

Model PMA rappers are designed for electrostatic precipitator applications. They have proven to be most economical, yet effective devices for these difficult applications. They produce higher frequencies while consuming less air than similar products. The PMA features a tapered mount that conforms to most rapper shaft and adapter designs. These vibrators are internally coated for enhanced performance.

The PMA's technical data is as follows: length 13" (33.0 cm), diameter 4.5" (11.4 cm), piston diameter 3" (7.6 cm), inlet port 3/8" NPT, output ports (2) two 1/2" (1.2 cm), weight 40 lbs. (18 kg), frequency 3000 VPM, air consumption 8.3 SCFM (235 lpm) and normal operating pressure 20 to 40 PSI (1.4 to 2.7 bar).

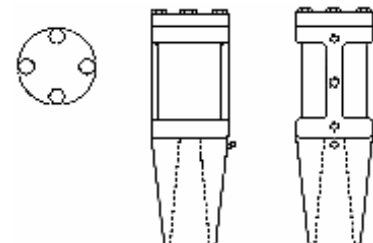

GENERAL DESCRIPTION OF BALL VIBRATORS

The Cleveland Vibrator Company offers a wide range of ball vibrators designed to keep stubborn materials flowing. These vibrators are powered by dry, compressed air. They produce a centrifugal force which makes them ideal for a number of applications.

Ball vibrators are most commonly used as discharge flow aids on small to medium-size bins, hoppers and chutes.

They are used in a variety of applications within the chemical, foundry and concrete industries.

Ball vibrators feature a high quality ductile iron housing. These bodies are designed to quickly and easily mount to equipment. Several models (VBB, VBC and E) have a base which allows them to be attached at a right angle or parallel to the mounting surface. Compressed air propels the steel ball in an orbit which creates the centrifugal force.

Econ-O-Line vibrators (VBB, VBC, VBD) utilize stainless steel race covers. The ball rides on the edges of these race covers. A through bolt is used to hold the covers in place and space them properly. The exhausting air escapes through two holes in the

exhaust race cover. The exhaust holes are covered by a poly sponge material or O-ring to dampen noise and prevent contamination. The sponge or o-ring is held in place by a deflector nut which uniformly discharges the exhausting air. These vibrators are supplied with a piped inlet port. A piped exhaust port is optional.

VBM incorporates features of the Econ-O-Line vibrators with the addition of a piped exhaust port and exhaust muffler. The exhausting air is directed through the muffler to further reduce the noise level. Another version of the VBM is the nylon-coated VBM-P vibrator. The entire unit is encapsulated with a heavy-duty nylon coating. The VBM-P is ideal for applications that require a sanitary, corrosion-resistant vibrator. Nickel plating provides an alternative coating for corrosion resistance. This vibrator is also supplied with an exhaust muffler.

The Herc-U-Line vibrators (E, F and U) feature pressed-in raceways. This provides a curved track for the steel balls. Non-metallic covers keep the balls in the track. The covers are held in place with snap rings. This design promotes longer vibrator life and

quieter operation. These vibrators are supplied with piped inlets and outlets and an exhaust muffler

Ball vibrators require a quick-acting valve to start and stop. The valve can be a manual type, activated by hand, knee or foot. An electrically-controlled solenoid type valve activated by a switch or push button is also available. The valve should be located within ten feet of the vibrator(s).

The ball vibrators should be controlled through an FR (Filter-Regulator). The filter keeps the air clean and dry. The regulator allows adjustment of the air pressure which in turn varies the force and frequency of vibration. Lubricated air is not required to operate ball vibrators, but is suggested for longer life.

Ball vibrators are suitable for operation in hazardous areas. They are ideal for atmospheres containing explosive dust, vapor or gas. These vibrators must be activated by an explosion-proof valve to ensure safe operation in hazardous areas.

VBB, VBC, & VBD

ECON-O-LINE

Model VBB is a small, high-speed vibrator that is applicable wherever a low-cost vibrator is needed to free materials that hang up. The VBB is available in a range of sizes that can be used on delicate laboratory equipment, as well as on small bins and hoppers. Just one bolt is needed to mount the VBB at a right angle or parallel to the surface to which it is attached.

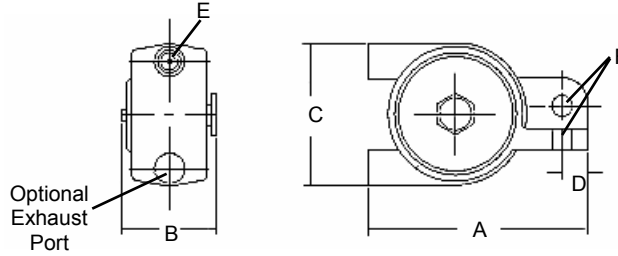

VBB				
	30 in/cm	40 in/cm	50 in/cm	80 in/cm
A	3-1/8 7.9	3-9/16 9.0	4.0 10.2	5-3/8 13.7
B	1-1/8 2.9	1-5/16 3.3	1-5/16 3.3	1-13/16 4.6
C	1-3/4 4.4	2-1/8 5.4	2-1/2 6.4	3-1/2 8.9
D	1/2 1.3	1/2 1.3	5/8 1.6	5/8 1.6
E	1/8 NPT	1/4 NPT	1/4 NPT	1/4 NPT
F	5/16 0.8	3/8 1.0	3/8 1.0	1/2 1.3

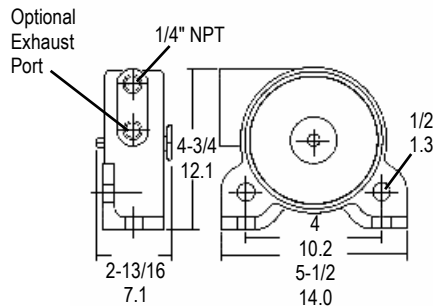

Model VBC is designed to mount at a right angle or parallel to the surface to which it is attached. A powerful vibrator for its size, the VBC moves stubborn materials from

medium-size (approximately 1/2 ton) hoppers and bins. Also suitable for use on small test tables and plastic or concrete forms.

Model VBD is available in two sizes. Both are heavy-duty vibrators that may be used on large bins and hoppers of rugged construction. VBD models feature a four-bolt flange mounting base. They mount quickly and easily with equipment that is available in kit form.

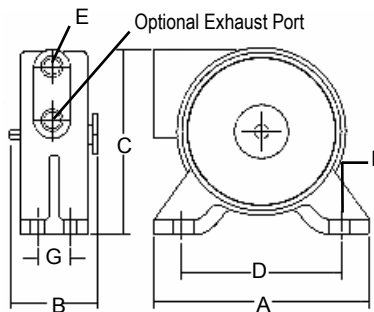

VBD		
	130 in/cm	150 in/cm
A	6-1/2 16.5	6-1/2 16.5
B	2-9/16 6.5	3.0 7.6
C	4-3/4 12.1	5-1/2 14.0
D	5-1/2 14.0	5-1/2 14.0
E	3/8 NPT	3/8 1.0
F	3/8 1.0	3/8 NPT
G	1-1/4 3.2	1-3/4 4.4

VBB • VBC • VBD																
MODEL	WT. lbs/kg	UN- BALANCE in lbs cm kg	psi/bar Req'd TO START		@20 psi/1.4 bar			@40 psi/2.7 bar			@60 psi/4.1 bar			@80 psi/5.4 bar		
			VERT	HORIZ	SPEED* vpm	FORCE lbs/kg	AIR CNSMP. cfm/lpm	SPEED* vpm	FORCE lbs/kg	AIR CNSMP. cfm/lpm	SPEED* vpm	FORCE lbs/kg	AIR CNSMP. cfm/lpm	SPEED* vpm	FORCE lbs/kg	AIR CNSMP. cfm/lpm
VBB-30	3/4 0.3	.008 1.3	5.0 0.3	2.0 0.1	10,000	23 10	3.0 85	15,000	51 23	5.0 142	20,000	91 41	8.0 227	n/a	n/a	n/a
VBB-50	1.0 0.5	.020 3.3	15 1.0	10 0.7	9,000	46 21	4.0 113	13,000	96 44	6.0 170	16,000	145 66	9.0 255	18,000	184 83	12 340
VBB-80	2-1/2 1.1	.114 19.0	35 2.4	20 1.4	7,000	159 72	6.0 170	7700	192 87	10 283	8,400	228 103	14 396	9,000	262 119	18 510
VBC-110	4.0 1.8	.351 58.0	60 4.1	30 2.0	3,600	129 59	8.0 227	4,800	230 104	12 340	6,200	383 174	15 425	7,500	560 254	25 708
VBD-130	5.0 2.3	.654 109	65 4.4	25 1.7	3,500	234 106	9.0 255	4,500	376 171	15 425	6,000	668 303	21 595	7,000	910 413	30 850
VBD-150	8.0 3.6	1.22 202	80 5.4	30 2.0	3,500	311 141	15 425	4,000	554 251	20 566	4,500	700 318	30 850	5,200	935 424	40 1133

*Frequency data obtained through testing under a no-load condition. Frequency will decline as load is increased.

VBM, VBM-P, & 110 DRUM VIBRATOR

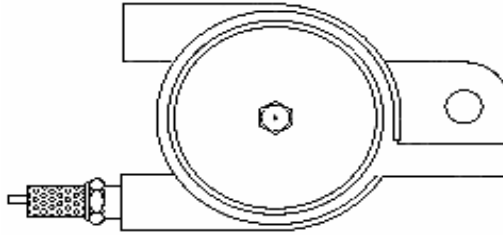

VBM ball vibrators incorporate the economy and efficiency of the Econ-O-Line series, with the quietness of an exhaust muffler. The standard muffler includes a built-in air regulator to control vibration intensity and frequency. The dimensional and technical data for the VBM data are the same as comparable Econ-O-Line models, but the noise level is much lower.

VBM-P models are nylon-coated ball vibrators with enclosed exhaust. The heavy-duty nylon coating encapsulates the entire vibrator. The VBM-P is ideal for applications that require a sanitary, corrosion-resistant vibrator. We also offer additional coatings for harsh environments including nickel, nitrofusion, ceramic, super blue and black coatings.

An exhaust muffler with built-in regulator is standard on the VBM-P. Dimensional and technical data for the VBM-P models are the same as comparable Econ-O-Line models, with the exception of noise levels.

INSTALLATION OF ECON-O-LINE

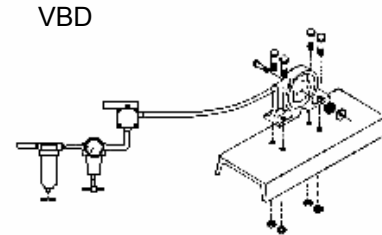
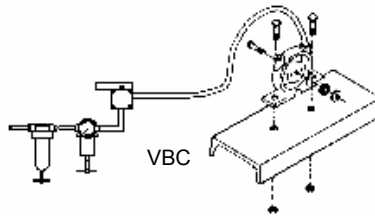
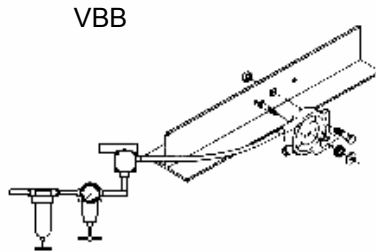

110 DRUM VIBRATOR

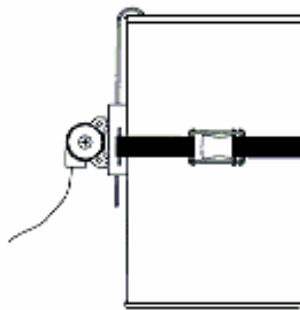

Hang and Hold Drum Vibrator Assembly Model 110 Drum Assembly allows quick attachment and removal of its powerful VBC-110 ball vibrator on fiber or steel drums. This model is ideal for settling materials to provide accurate shipping weights and/or to increase capacity. It fits containers up to 30" (76 cm) in diameter and develops sufficient vibratory force to agi-

tate loads of up to 300 lbs (136 kg).

A strong web belt and ratchet insure a secure attachment for maximum transfer of vibration. An adjustable support hook allows the operator to work the ratchet without having to support the vibrator. The kit includes a ball vibrator (frequency 3600 to 7500 VPM), special mounting plate, adjustable web belt with ratchet type

buckle, adjustable hook, 5' (152 cm) neoprene hose with fittings, QN quick acting valve, air-pressure regulator and filter assembly. The approximate weight is 15 lbs (6.8 kg).

Larger size Vibra-Balls also available. Call sales for details.

E, F, & U

HERC-U-LINE

Lightweight Series E ball vibrators produce penetrating high-frequency vibration. Ball vibrators are commonly

used with laboratory equipment, small pill and feed boxes, hoppers and chutes. Series E ball vibrators can be

mounted at a right angle, or parallel to the surface to which they are attached, with a single bolt.

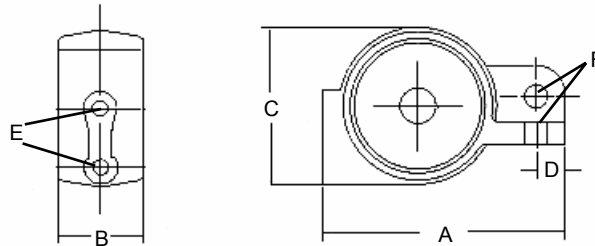

E	10 in/cm	13 in/cm	16 in/cm	19 in/cm	25 in/cm
A	3 7.6	3-11/16 9.4	4.0 10.2	4-1/2 11.4	5-5/8 14.3
B	1-3/16 3.0	1-5/16 8.4	1-3/8 3.5	1-11/16 4.3	2-15/16 5.9
C	2.0 5.1	2-3/8 6.0	2-1/2 6.4	2-15/16 7.5	3-13/16 9.7
D	1/2 1.3	9/16 1.4	5/8 1.6	1/2 1.3	3/4 1.9
E	1/8 NPT	1/8 NPT	1/4 NPT	1/4 NPT	1/4 NPT
F	5/16 0.8	3/8 1.0	3/8 1.0	3/8 1.0	1/2 1.3

Model F ball vibrators feature horizontal inlet and outlet ports and a two-bolt or four-bolt flange base. Like all Herc-U-Line ball vibrators, the F ball vibrators have no center bolt hole. The side plates are positioned by retaining rings. The two-bolt F-35 ball

vibrator is designed to move the most stubborn materials in a minimum of space.

The four-bolt flange base of models F-41 and F-51 ball vibrators provides a sturdy attachment for heavy-duty use on chutes, screens,

bins or hoppers. The F-51 ball vibrator delivers a walloping 802 lbs. force at 80 PSI. Threaded inlet and outlet ports, a feature of all Herc-U-Line ball vibrators, provide easy installation of hose or muffler.

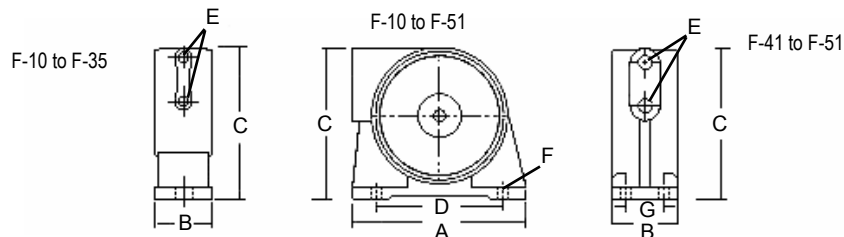

F	10 in/cm	13 in/cm	19 in/cm	25 in/cm	35 in/cm	41 in/cm	51 in/cm
A	3-5/16 10.0	5-1/16 12.9	5-1/8 13.0	6-3/8 16.2	5-3/8 13.7	6-3/8 16.2	6-3/8 16.2
B	1-3/16 3.0	1-5/16 3.3	1-11/16 4.3	2-5/16 5.9	2-1/8 5.4	3-1/8 7.9	3-1/8 7.9
C	2-3/16 5.6	2-5/8 6.7	3-5/16 8.4	4-3/8 11.1	4-1/4 10.8	6.0 15.2	6.0 15.2
D	3.0 7.6	4.0 10.2	4.0 10.2	4.5 10.2-12.7	4.0 10.2	5-1/2 14.0	5-1/2 14.0
E	1/8 NPT	1/8 NPT	1/4 NPT	1/4 NPT	1/4 NPT	3/8 NPT	3/8 NPT
F	5/16 0.8	3/8 1.0	3/8 1.0	1/2 1.3	1/2 1.3	3/8 1.0	3/8 1.0
G	n/a	n/a	n/a	n/a	n/a	1-1/4 - 1-3/4 3.2-4.4	1-1/4 - 1-3/4 3.2-4.4

E, F & U continued

Series U ball vibrators, available in seven sizes, are designed with vertical inlet and outlet ports. A two-bolt flange

base secures these vibrators. As with all Herc-U-Line models, the raceways of the Series U can be removed and

replaced, providing exceptional value and long vibrator life.

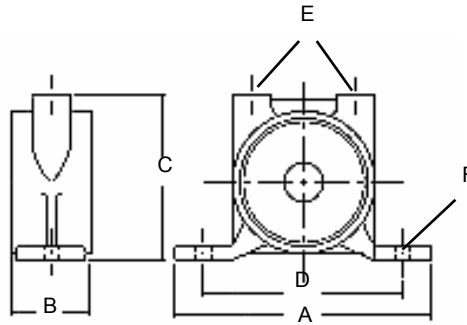

U	6 in/cm	13 in/cm	19 in/cm	25 in/cm	32 in/cm	38 in/cm	44 in/cm
A	3-3/4 9.5	5.0 12.7	5.0 12.7	6.0 15.2	6.0 15.2	7-3/4 19.7	8-1/2 21.6
B	1-1/8 2.9	1-1/4 3.2	1-5/8 4.1	2-1/4 5.7	2-1/4 5.7	2-3/4 7.0	3.0 7.6
C	2-1/8 5.4	2-1/2 6.4	3-3/16 8.1	4-1/8 10.5	4-1/8 10.5	5.0 12.7	5-3/4 14.6
D	3.0 7.6	4.0 10.2	4.0 10.2	5.0 12.7	5.0 12.7	6.0 15.2	7.0 17.8
E	1/8 NPT	1/8 NPT	1/4 NPT	1/4 NPT	3/8 NPT	3/8 NPT	1/2 NPT
F	1/4 0.6	3/8 1.0	3/8 1.0	1/2 1.3	1/2 1.3	5/8 1.6	5/8 1.6

E • F • U																
MODEL	WT. lbs/kg	UN- BALANCE in lbs/ cm kg	psi/bar Req'd TO START		@20 psi/1.4 bar			@40 psi/2.7 bar			@60 psi/4.1 bar			@80 psi/5.4 bar		
			VERT	HORIZ	SPEED* vpm	FORCE lbs/kg	AIR CNSMP. cfm/lpm	SPEED* vpm	FORCE lbs/kg	AIR CNSMP. cfm/lpm	SPEED* vpm	FORCE lbs/kg	AIR CNSMP. cfm/lpm	SPEED* vpm	FORCE lbs/kg	AIR CNSMP. cfm/lpm
E10	.75 .03	.003 0.5	5.0 0.3	4.0 0.3	15,750	21 9.5	3.3 93	21,000	37 17	6.4 181	23,000	45 20	6.4 181	24,000	49 22	8.4 238
E13	1.0 0.5	.008 1.3	10 0.7	5.0 0.3	13,000	38 17	4.2 119	17,500	70 32	6.6 187	19,500	86 39	8.8 249	20,000	91 41	11 312
E16	1-1/2 0.7	.020 3.3	15 1.0	3.0 0.2	11,000	69 31	3.0 85	13,000	96 44	6.0 170	16,500	154 70	8.0 227	17,000	164 74	11 312
E19	2.0 0.9	.037 6.1	13 0.9	5.0 0.3	8,750	80 36	5.2 147	10,500	116 53	8.3 255	15,000	236 107	11.2 317	16,000	269 122	16 453
E25	5.0 2.3	.116 19	19 1.3	5.0 0.3	7,400	180 82	6.6 187	10,000	329 149	10 283	11,000	399 181	14.1 399	12,500	515 234	18 510
F10	.75 0.3	.003 0.5	20 1.4	12 0.8	9,500	8.0 3.6	2.8 78	15,000	19 8.6	4.3 122	15,500	20 9.1	6.0 170	19,000	31 14	7.5 212
F13	1-1/2 0.7	.008 1.3	18 1.2	3.0 0.2	8,600	17 7.7	3.7 105	13,000	38 17	5.9 167	15,100	52 24	8.1 229	17,000	66 30	10 283
F19	2-1/2 1.1	.037 6.1	20 1.4	5.0 0.3	10,000	105 48	4.9 139	13,000	177 80	8.2 272	15,000	236 24	11 312	15,500	252 114	14 396
F25	5-1/2 2.5	.116 19	41 2.8	5.0 0.3	6,400	135 61	5.8 164	8,100	216 98	9.4 266	9,700	313 142	13 368	11,100	406 184	16 453
F35	6.0 2.7	.210 35	41 2.8	5.0 0.3	7,000	292 132	7.1 201	8,200	401 182	11 312	10,750	689 313	15 425	11,500	789 358	19 538
F41	15 6.8	.750 124	65 4.4	5.0 0.3	3,000	192 87	10.4 295	4,000	341 155	17 481	5,000	533 242	21 595	5,500	644 292	29 821
F51	15 6.8	1.13 187	84 5.7	5.0 0.3	2,100	142 64	10.4 295	3,000	289 131	17 481	3,600	416 189	23 651	5,000	802 364	24 821
U6	.75 0.3	.001 0.2	1.0 0.1	1.0 0.1	17,000	8.0 3.6	2.0 57	22,000	14 6.4	3.5 99	25,000	18 8.2	4.5 127	26,000	19 8.6	6.0 170
U13	1-1/2 0.7	.008 1.3	10 0.7	5.0 0.3	13,000	38 17	4.2 119	15,000	51 23	5.0 142	20,000	90 41	7.5 212	12,000	100 45	11 312
U19	2-1/2 1.1	.037 6.1	13 0.9	5.0 0.3	10,500	116 53	4.0 113	14,000	205 93	7.0 198	16,000	270 122	11 312	17,000	303 137	14 396
U25	5.0 2.3	.116 19	19 1.3	5.0 0.3	7,400	180 82	6.6 187	9,700	309 140	10 283	11,000	398 181	13 368	12,000	474 215	16 453
U32	6.0 2.7	.240 40	30 2.0	5.0 0.3	5,100	178 81	6.0 170	6,500	288 131	11 312	7,500	383 174	17 481	11,500	901 409	19 538
U38	9.0 4.1	.480 80	50 3.4	5.0 0.3	4,200	240 109	7.0 198	5,500	412 187	14 396	6,200	524 238	20 566	10,000	1363 618	25 708
U44	13 5.9	.915 152	60 4.1	5.0 0.3	3,200	266 121	9.0 255	5,100	675 306	15 425	6,000	935 424	21 595	6,500	1097 498	26 736

ACCESSORIES AND REPAIR SERVICES

SN SOLENOID VALVE

These are electric 2-way, normally closed, internal pilot-operated solenoid valves. They are supplied with a Type 1 General Purpose Solenoid Enclosure. We offer 1/4", 3/8", 1/2" and 3/4" NPT

sizes suitable for 110/1/60 operation. These valves are of brass construction. Special voltages and enclosures are available.

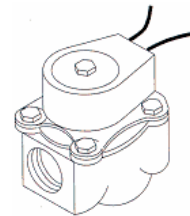

QN QUICK DISCONNECT VALVE

These manual valves are normally used to operate portable vibrators. They are not much larger than the hose diameter. There are no springs or washers to interrupt the

flow of air. They will not fly apart when uncoupled. We offer 1/4", 3/8", 1/2" and 3/4" NPT sizes. These valves are constructed of plated steel.

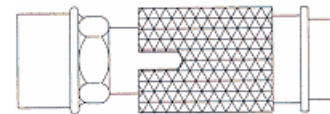

J KNEE VALVE

These quick-acting, normally closed valves are an alternate to the JN hand valves offered in our complete kits. They flange mount anywhere an operator

requires knee control. We offer 1/4" and 3/8" NPT sizes. These valves are all brass construction except for the steel knee lever and sponge rubber pad.

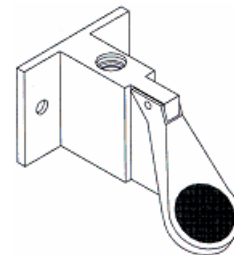

RECYCLE TIMERS

These general-purpose timers offer short bursts of vibration at regular intervals where constant vibration may not be desirable. We offer a variety of adjustable cycles for

both the ON time and the OFF time. These timers are suitable for 110/1/60 operation and are supplied in a NEMA 12 enclosure. Special voltages and enclosures are also available.

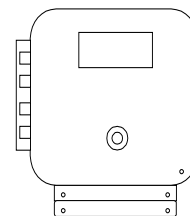

SWIVEL CONNECTIONS AIRTIGHT - 360° SWIVEL RUGGED, INDUSTRIAL TYPE

Swivel connections increase efficiency in handling all pneumatic tools and eliminate wrist strain and tired, cramped hands when working with air hammers, rammers, grinders, chippers, paving breakers, etc. They also allow users to change tools quickly and easily. Additionally, swivel connections increase hose life by eliminating kinking and buckling. The connections are airtight, all steel and rust-proofed.

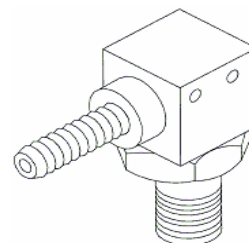

SIZES AVAILABLE

1/4" NPT x 1/4" HC

1/4" NPT x 3/8" HC

REPAIR SERVICE FOR AIR VIBRATORS

We offer a complete repair service for our air piston vibrators as well as a repair service for our competitors air piston vibrators. The typical air piston vibrator repair consists of reboring the body and fitting it with an oversized piston.

Our repair service consists of inspecting the mounting heads, gaskets, through bolts and springs, and replacing them as required. The cost of

repair service runs about 50% to 60% of the cost of a new unit.

The typical replacement parts for the Econ-O-Line ball vibrators include a ball, race covers and through bolt. Those parts for the Herc-U-Line models include the ball, raceways and O-rings. Ball vibrators are typically repaired in the field. We offer field repair kits for each of the Econ-O-Line and Herc-U-Line models.

Our vibrator repair service includes repair of competitive air-powered vibrators. We offer equivalent Cleveland Vibrator models to replace units that are beyond repair. To take advantage of our repair service, call our Toll Free number at 800-221-3298, Fax us at 216-241-3480 for a RGA (Returned Goods Authorization) or E-mail us. Once returned, we will furnish a written estimate of the cost of repair.