

**T850 &
T1050
TRUCK
BLOWERS**



QUIET, POWERFUL
PERFORMANCE



TUTHILL
Vacuum & Blower Systems



The T850 & T1050

The 'T' Series truck blowers are completely new products from the company that has pioneered and produced thousands of truck blowers.

Versatile

The T850 & T1050 are highly versatile with their ability to unload a variety of products from fine powders to food products to pebbles. With strong features including oil tanks at both ends, wide speed and flow capabilities, large driveshaft and bearings, and up to 20 psi capability, the T850 and T1050 are built tough for long lasting performance.

Quiet

T850s & T1050s are engineered with built-in silencing chambers for noise reduction.



Specifications	T850	T1050
Air Flow	390 - 1000 CFM	450 - 1300 CFM
Pressure	20 psi continuous	18 psi continuous
Vacuum	17" HG continuous	17" HG continuous
Blower Weight	340 pounds	380 pounds
Warranty	12 months	12 months

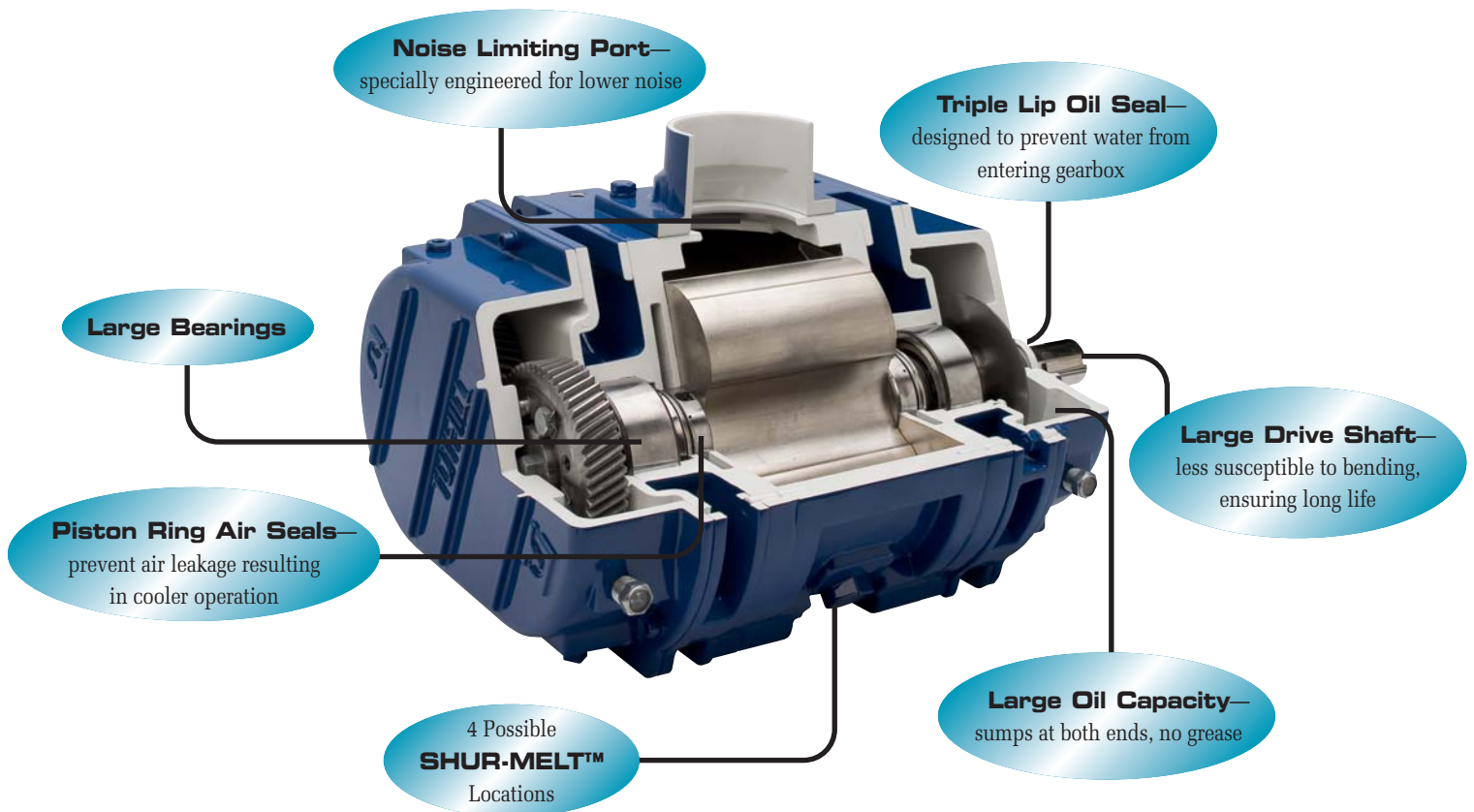

Mounting Kits—For All Applications

Installation is quick, simple and available for vertical or horizontal applications including vacuum loading, and pressure discharge as well as passenger and driver side mounting. Pre-cleaner kits, power take-offs, stainless steel silencers, and air-filters are also available.



▲ Horizontal Mounting Kits

SHUR-MELT™ Plugs

All T850 & T1050 blowers are specially equipped with our patented SHUR-MELT thermal relief plugs for heat and pressure protection. Upon activation, plugs will relieve 5-6 PSIG with a corresponding 80-100°F discharge temperature drop to protect blowers from damage. Plugs are located on the in-take and discharge side of the blowers.



Filter Silencers

Filter Silencers provide both intake silencing and filtration ensuring clean air reaches the blower. Vacuum loading and pressure discharge silencers are available in steel and stainless steel.



▼ Vertical Mounting Kits



▲ Vacuum Loading and Pressure Discharge

Packaged Units

The T850 & T1050 are also available as packaged units complete with components selected specifically for your application. Electric or engine driven options are available. For more information, please call 1-800-825-6937 for the distributor nearest you.

12-Month Limited Warranty

Each new T850 & T1050 carries a factory warranty for 12 months from date of initial use or 18 months from date of shipment to first purchaser, whichever occurs first. Tuthill Vacuum & Blower Systems warrants its T850 & T1050 model truck blowers to be free from defects in materials or workmanship.



T850 PRESSURE CURVE

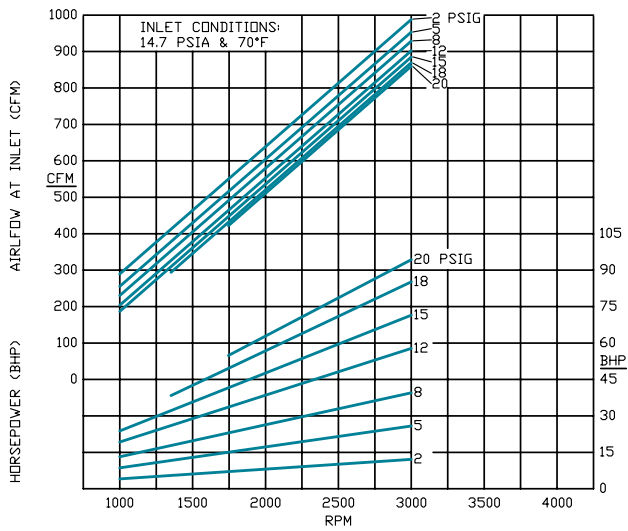

T1050 PRESSURE CURVE

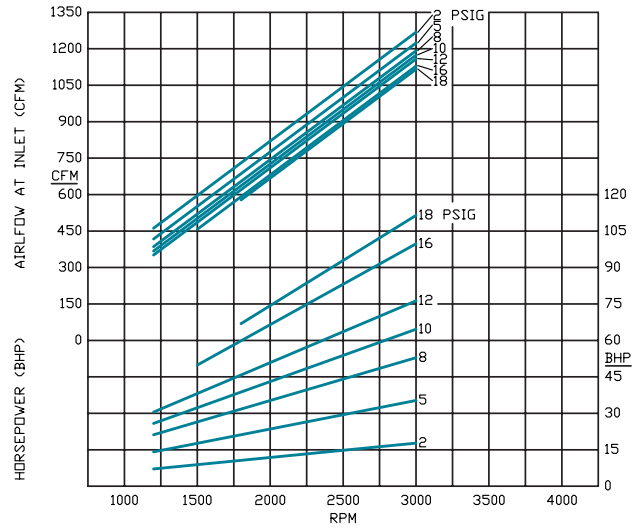

T850 VACUUM CURVE

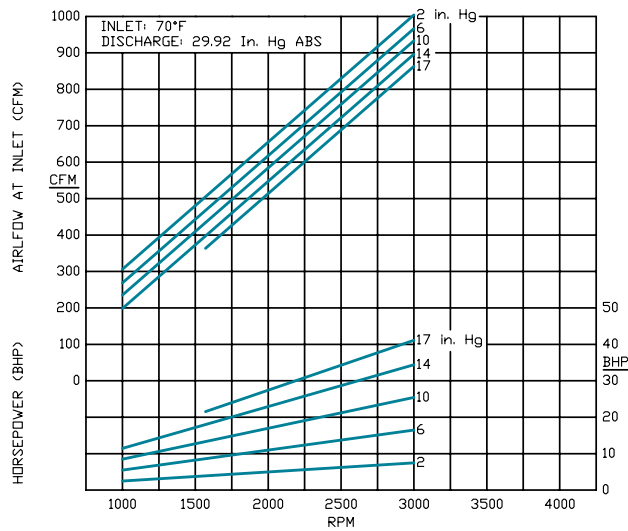

T1050 VACUUM CURVE

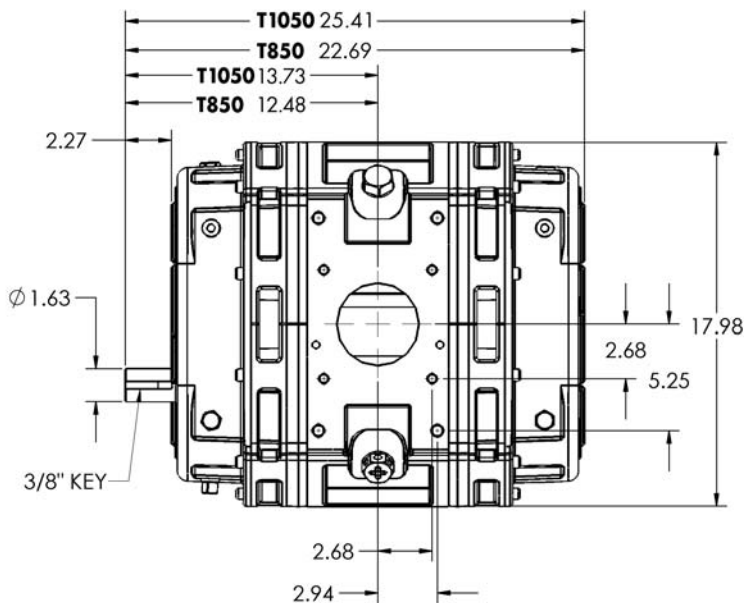
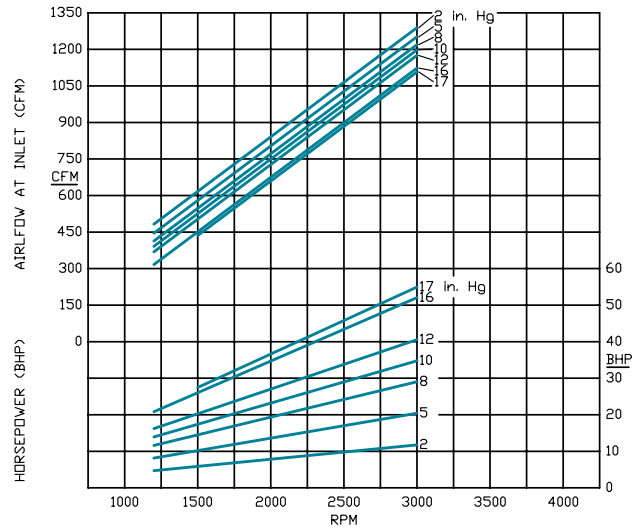

M-D Pneumatics™ Blowers and Vacuum Boosters

4840 West Kearney Street
Springfield, Missouri, USA 65803-8702
417-865-8715 • 1-800-825-6937
FAX: 417-865-2950
<http://vacuum.tuthill.com>
or www.truckblowers.com



Distributed by: